

JOHN
LEWIS
& PARTNERS

Cloud dresser

Stock number: 324 32301

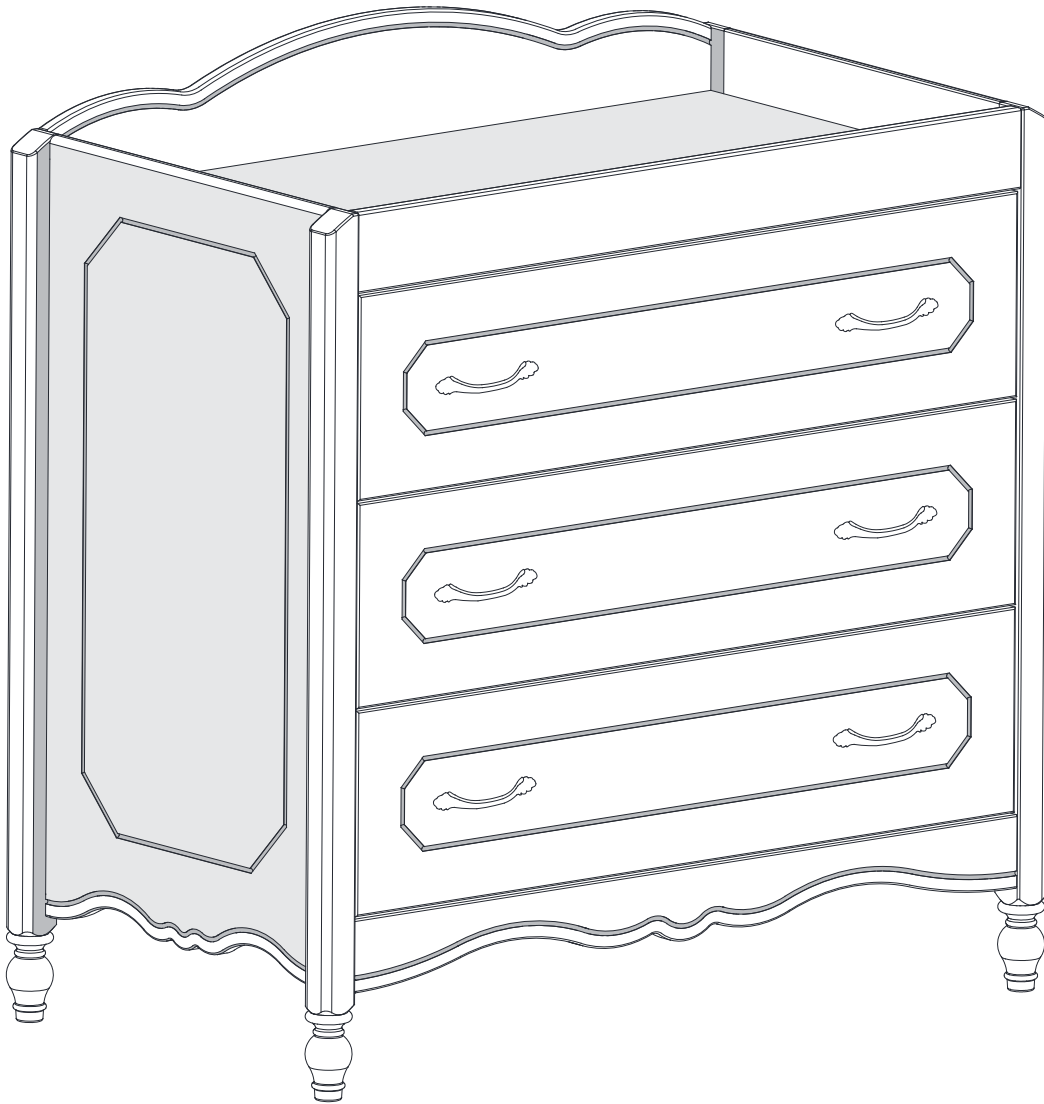

IMPORTANT RETAIN FOR FUTURE REFERENCE READ CAREFULLY

H103 W 99 D 56cm

Introduction

Thank you for purchasing this **Cloud** dresser.
Please read the instructions carefully before
use to ensure safe and satisfactory operation of this product.
Recommended changing mat: **900 mm × 510 mm**,
This changing unit complies with BSEN 12221:2008 + A1:2013.

Tools required

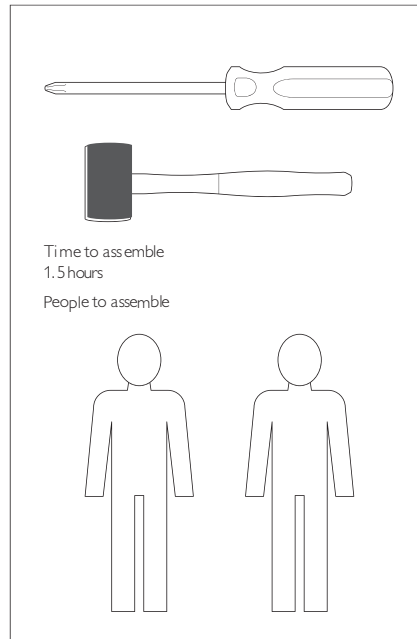

Important safety
information

⚠ Warning: In order to prevent overturning, this product must be used with the wall attachment device provided.

Serious or fatal crushing injuries can occur from furniture tipping over.
To help prevent topple over, please observe the following:

1. Use the wall attachment device provided
2. Never allow children to climb or hang on drawers, doors or shelves.
3. Place heaviest items in the lower drawers or shelves.
4. Never open more than one drawer at a time.

An attachment device is provided with your product; however, you will need to source suitable fixings for your wall type. If in doubt, please consult a qualified tradesperson.

Always ensure the wall to be drilled is free from hidden electrical wires, water and gas pipes.

Warnings

- ⚠ Assembly to be carried out by competent adult only.
- ⚠ The product should only be used on firm, level ground.
- ⚠ Keep small parts out of reach of children.
- ⚠ Ensure the product is fully assembled as illustrated before use.
- ⚠ Care should be taken that no screws are loose because a child could trap parts of their body, or clothing (e.g. strings, necklaces, ribbons, dummies, etc) which could pose a risk of strangulation.
- ⚠ Ensure that the wall strap is used to securely attach the wardrobe to the wall to prevent tipping.
- ⚠ Any additional or replacement parts must only be obtained from John Lewis & Partners.
- ⚠ During assembly children should be kept away from the product due to possible risk of injury.
- ⚠ Do not use this item if any components are missing or damaged.

Do's

- ✓ Check the pack and make sure you have all the parts listed.
- ✓ Check all screws or bolts are tightened and inspect regularly.
- ✓ Make sure the legs remain in contact with the ground at all times.

Don'ts

- ✗ Do not over tighten screws or bolts.
- ✗ Do not stand on the product.
- ✗ Do not use power tools to construct as over tightening and panel failure may occur.

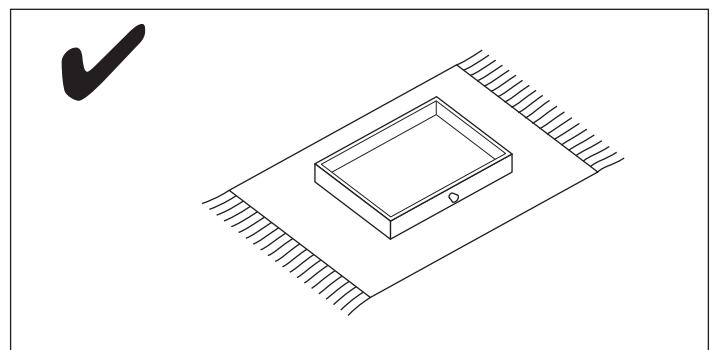
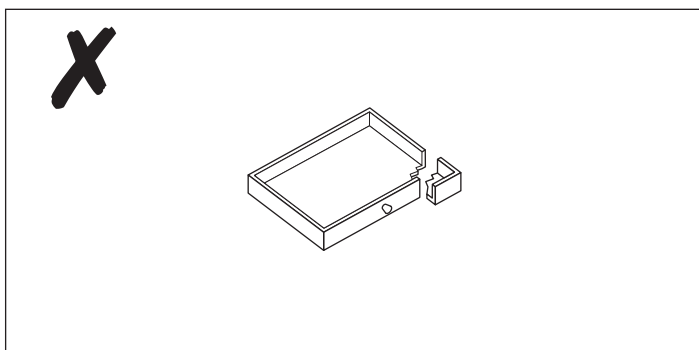
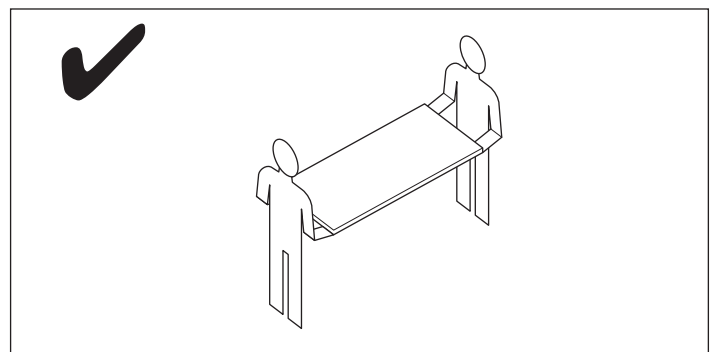
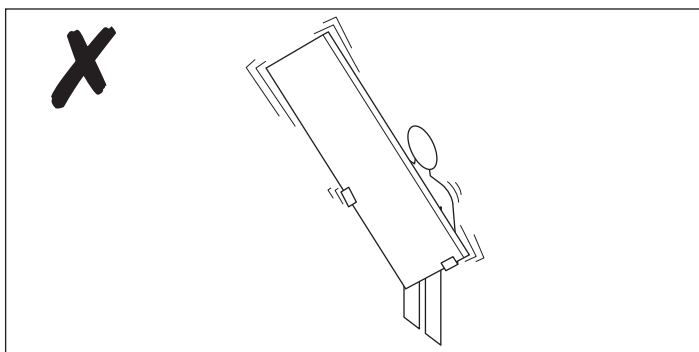
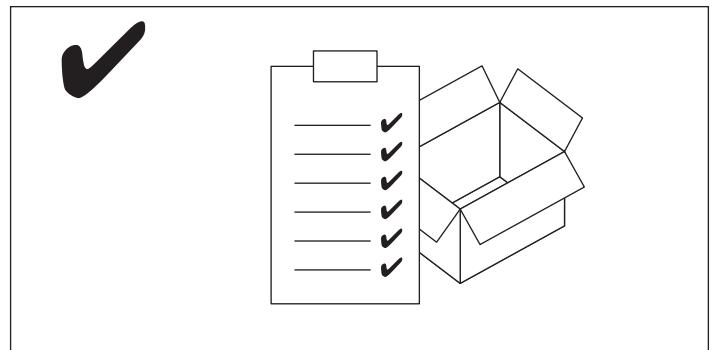
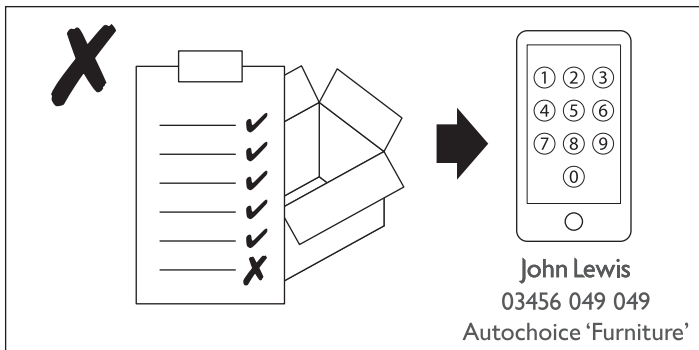

Your dresser

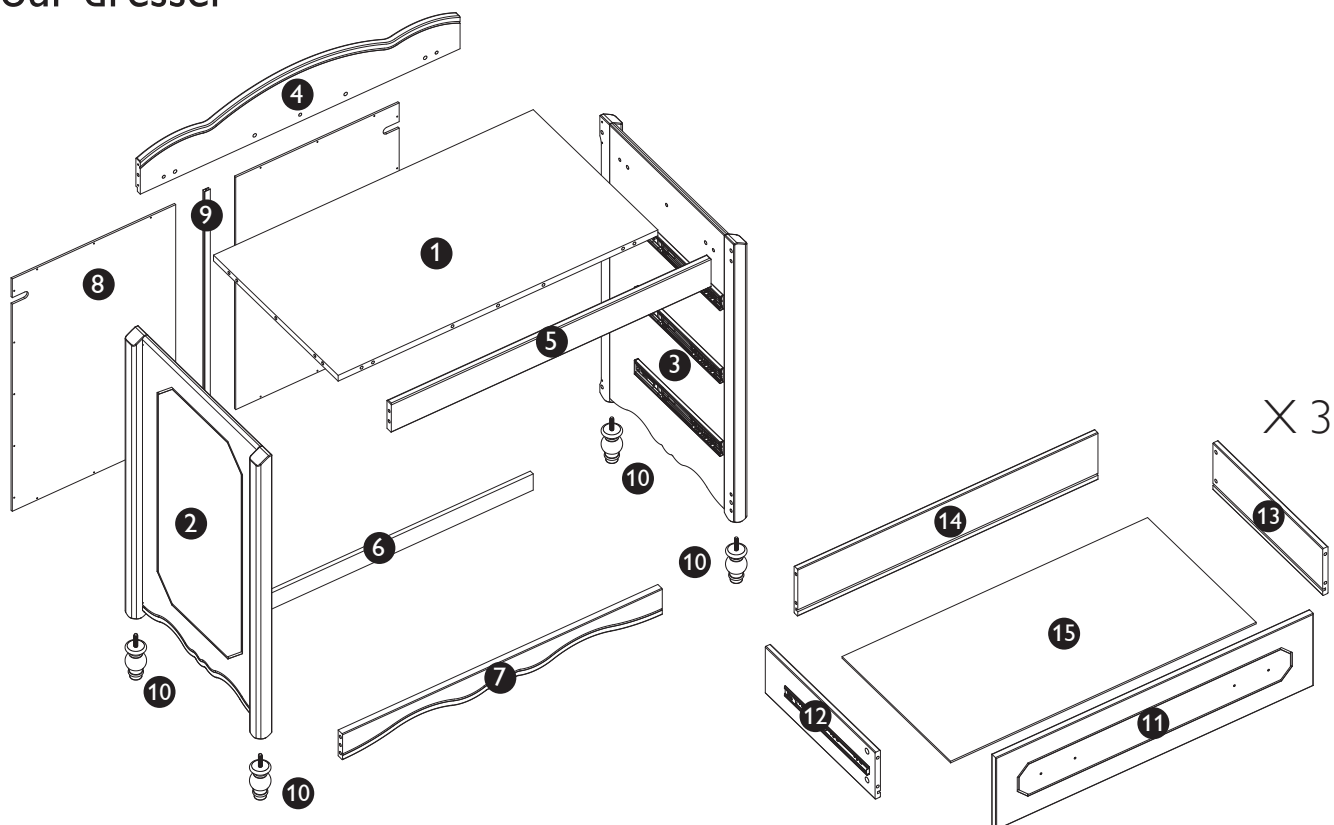

Ref	Description	Dimensions	Qty
①	Top panel	900mm x 511mm x 18mm	1
②	L/H side panel	867mm x 550mm x 40mm	1
③	R/H side panel	867mm x 550mm x 40mm	1
④	Top back rail	900mm x 170mm x 18mm	1
⑤	Top front rail	900mm x 88mm x 18mm	1
⑥	Bottom back rail	900mm x 50mm x 18mm	1
⑦	Bottom front rail	900mm x 80mm x 18mm	1
⑧	Back panel	719mm x 460mm x 5mm	2
⑨	Back Divider	717mm x 15mm x 7mm	1
⑩	Leg	Ø50mm x 95mm	4
⑪	Drawer Front	894mm x 223mm x 18mm	3
⑫	L/H drawer side panel	450mm x 145mm x 22mm	3
⑬	R/H drawer side panel	450mm x 145mm x 22mm	3
⑭	Drawer back	844mm x 145mm x 15mm	3
⑮	Drawer Base	859mm x 445mm x 5mm	3

Internal dimensions

Stock number : 324 32301

Dresser overall size: H103 W 99 D 56cm

Drawer size: H22 W 89 D 45cm



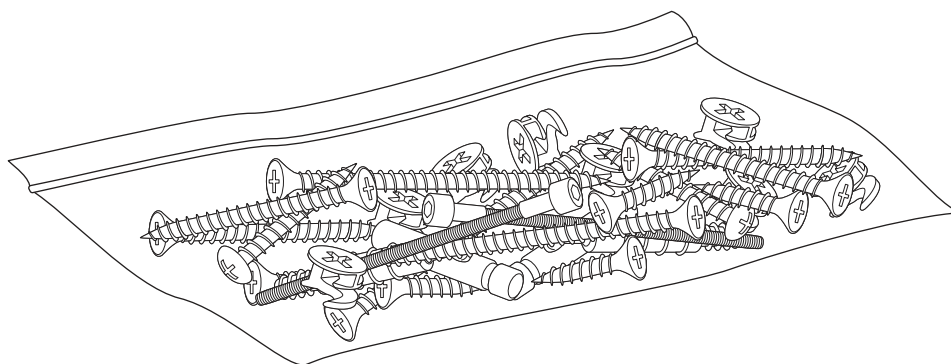

Fixtures and fittings

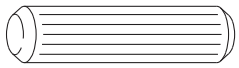
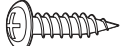
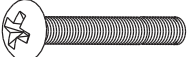
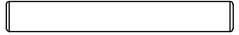

Fixtures and fittings
supplied (actual size)

Ref	Description	Dimensions	Qty	mm
A	Wooden dowels	8mm x 30mm	18	
B	Screw	3.5mm x 16mm	24	
C	Screw	4mm x 22mm	12	
D	Metal pin	4mm x 30mm	6	

Fixtures and fittings
supplied (not actual size)

Ref	Description	Dimensions	Qty	
H	Metal 'L' Bracket and screws to attach to product	73mm x 15mm x 24mm	2	
J	Cam heads	15mm x 11mm	44	
K	Cam rods	5mm x 33mm	44	
L	Handle		6	

Product assembly

cloud dresser

Step 1

Parts, fittings and tools

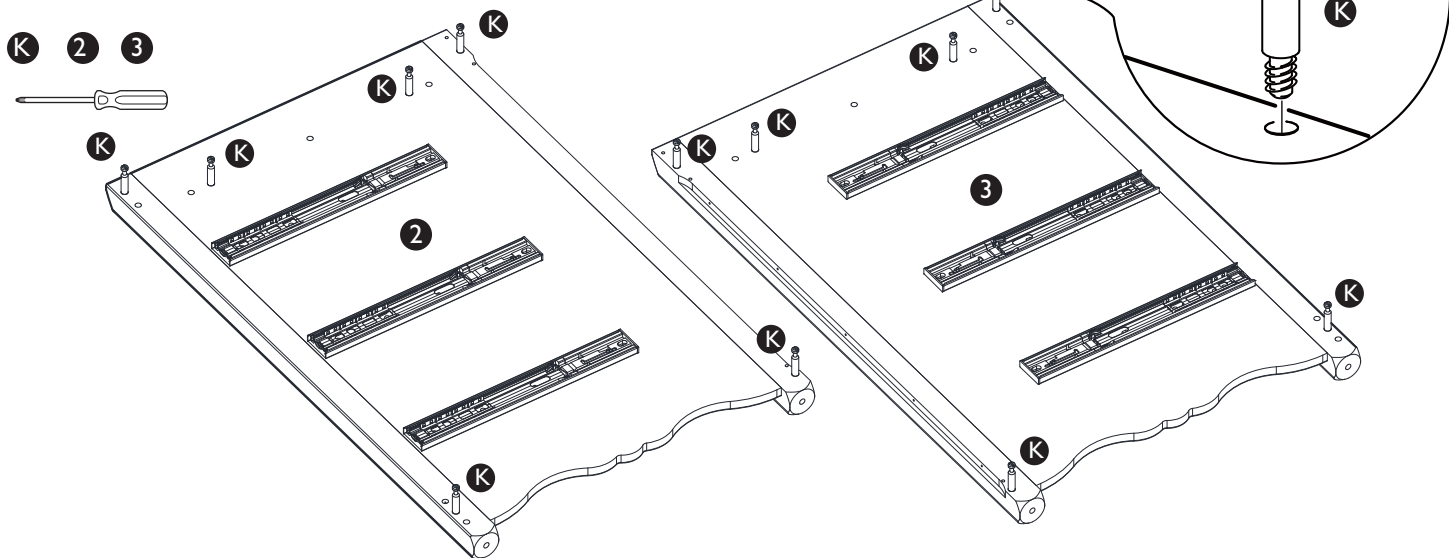

Step 2

Parts, fittings and tools

A K D 4 5

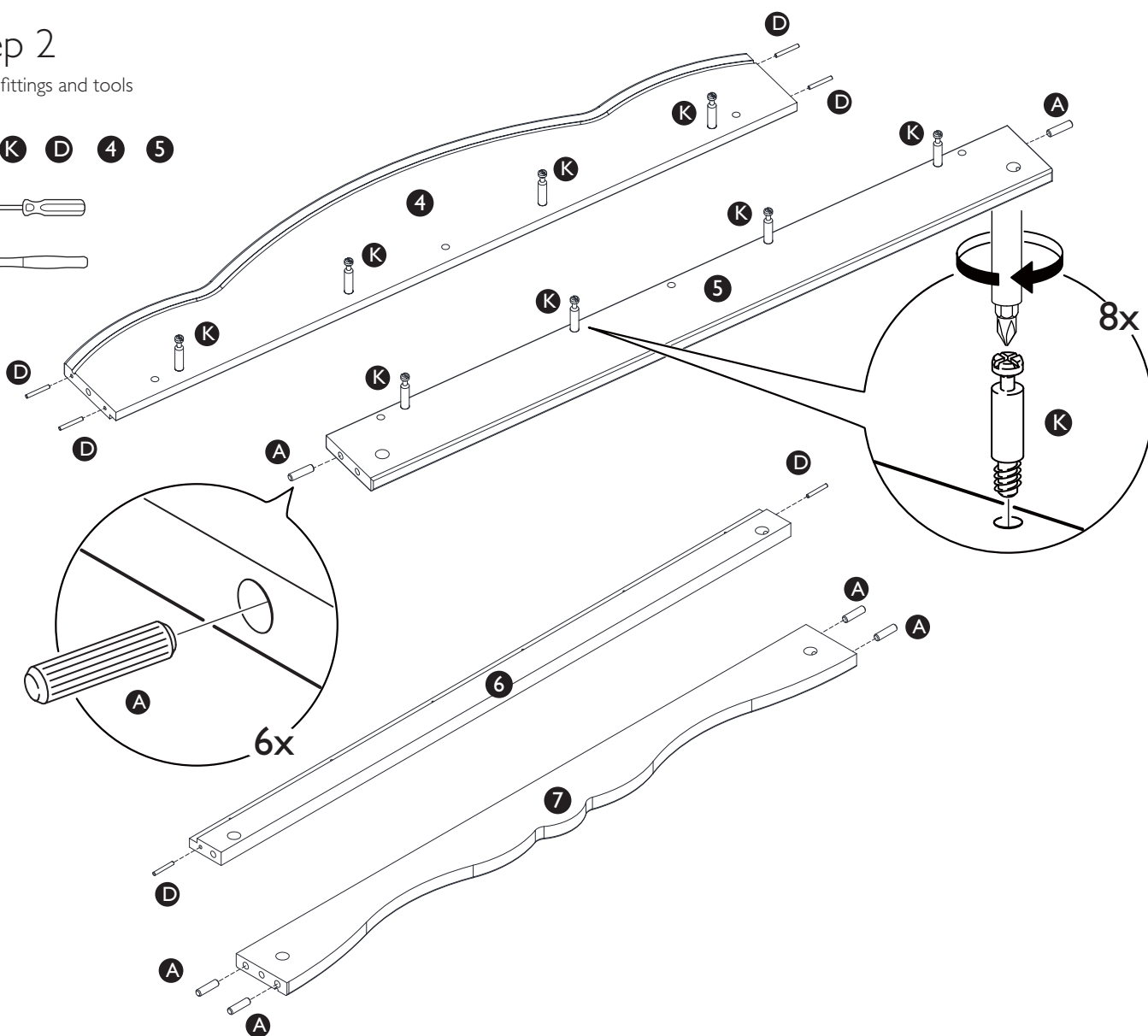
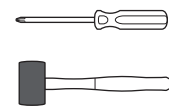

Product assembly

cloud dresser

Step 3

Parts, fittings and tools

B H 2 3 10

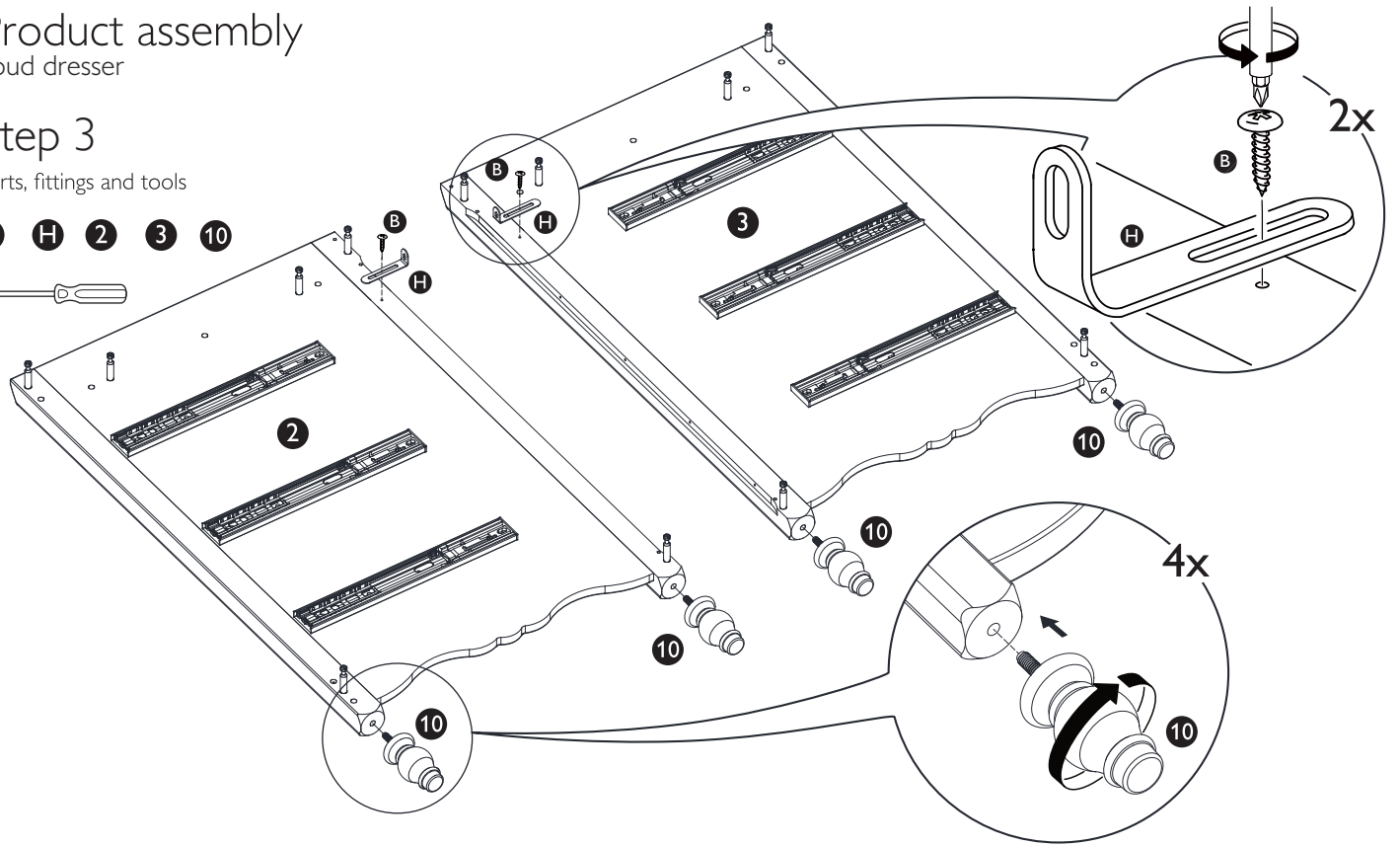
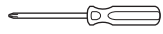

Step 4

Parts, fittings and tools

A J 1 4 5

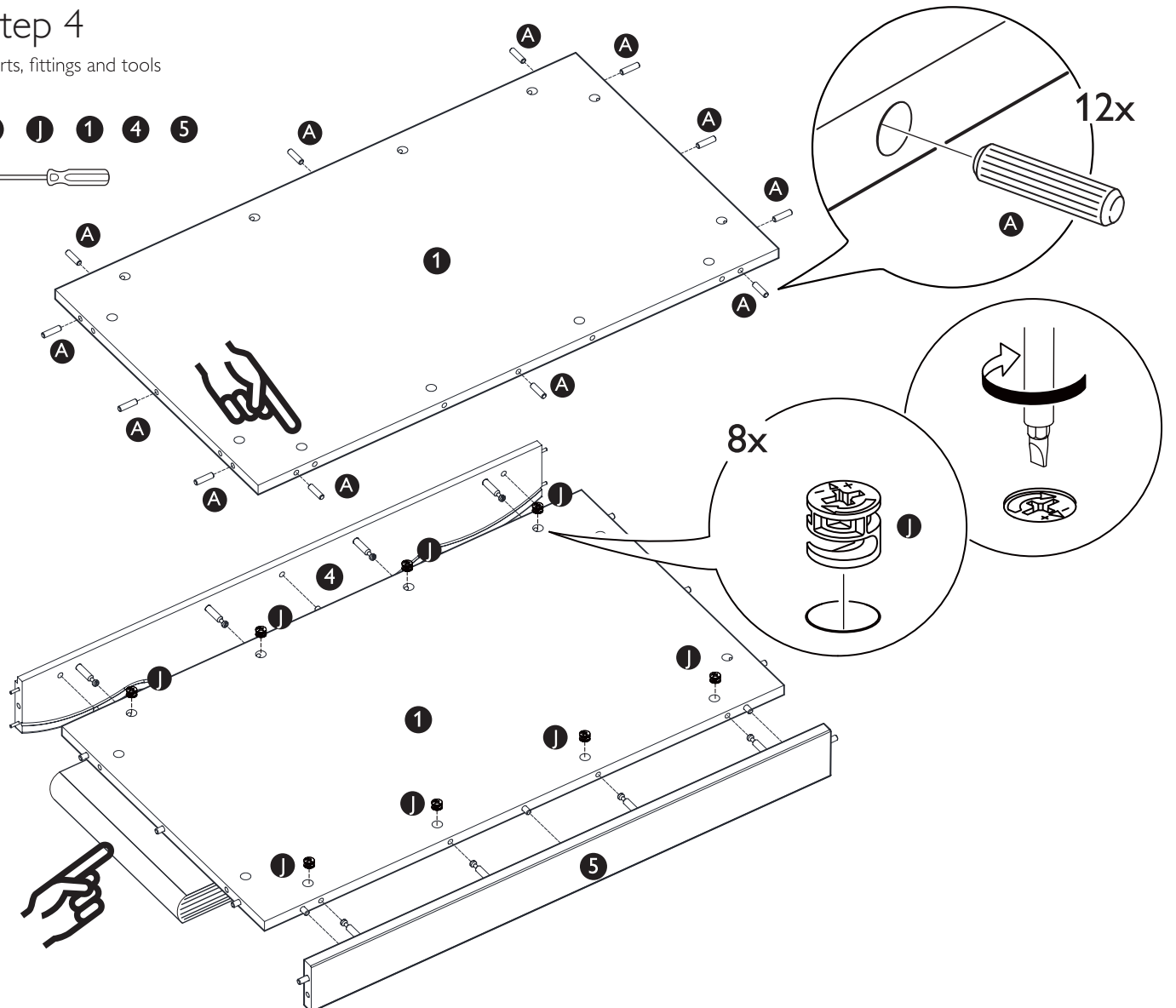
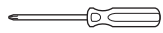

Product assembly

Cloud dresser

Step 5

Parts, fittings and tools

J 1 2 4

5 6 7

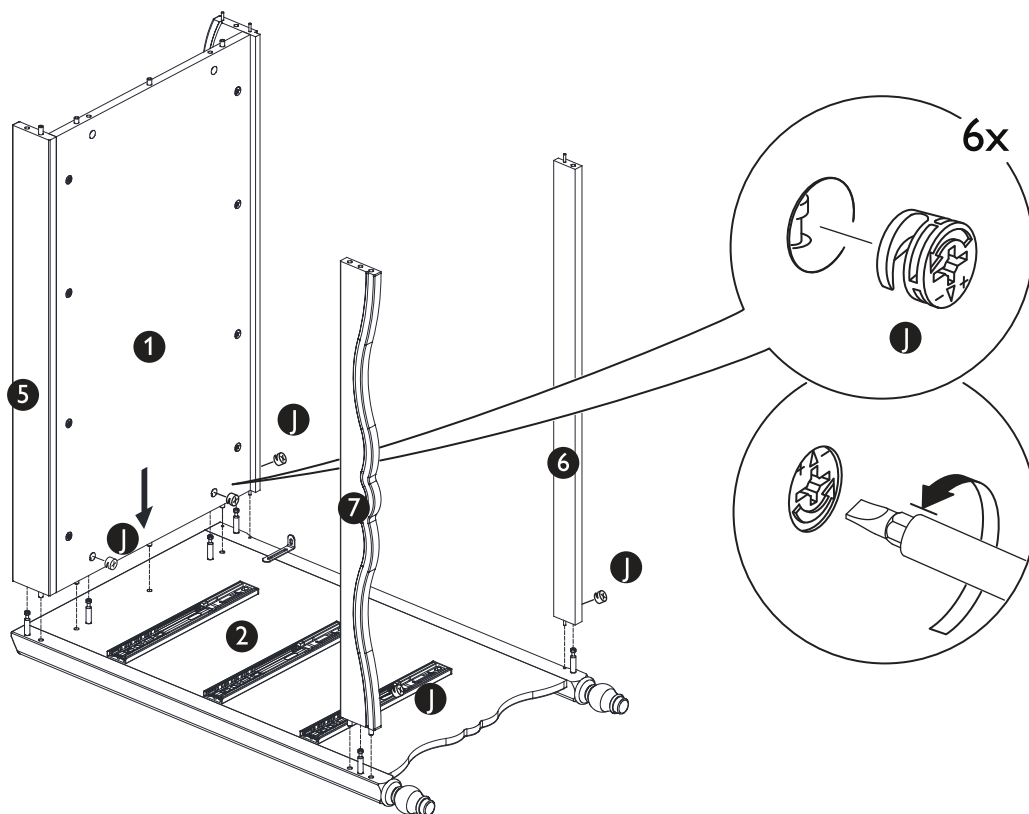
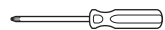

Step 6

Parts, fittings and tools

J 1 2 3 4

5 6 7

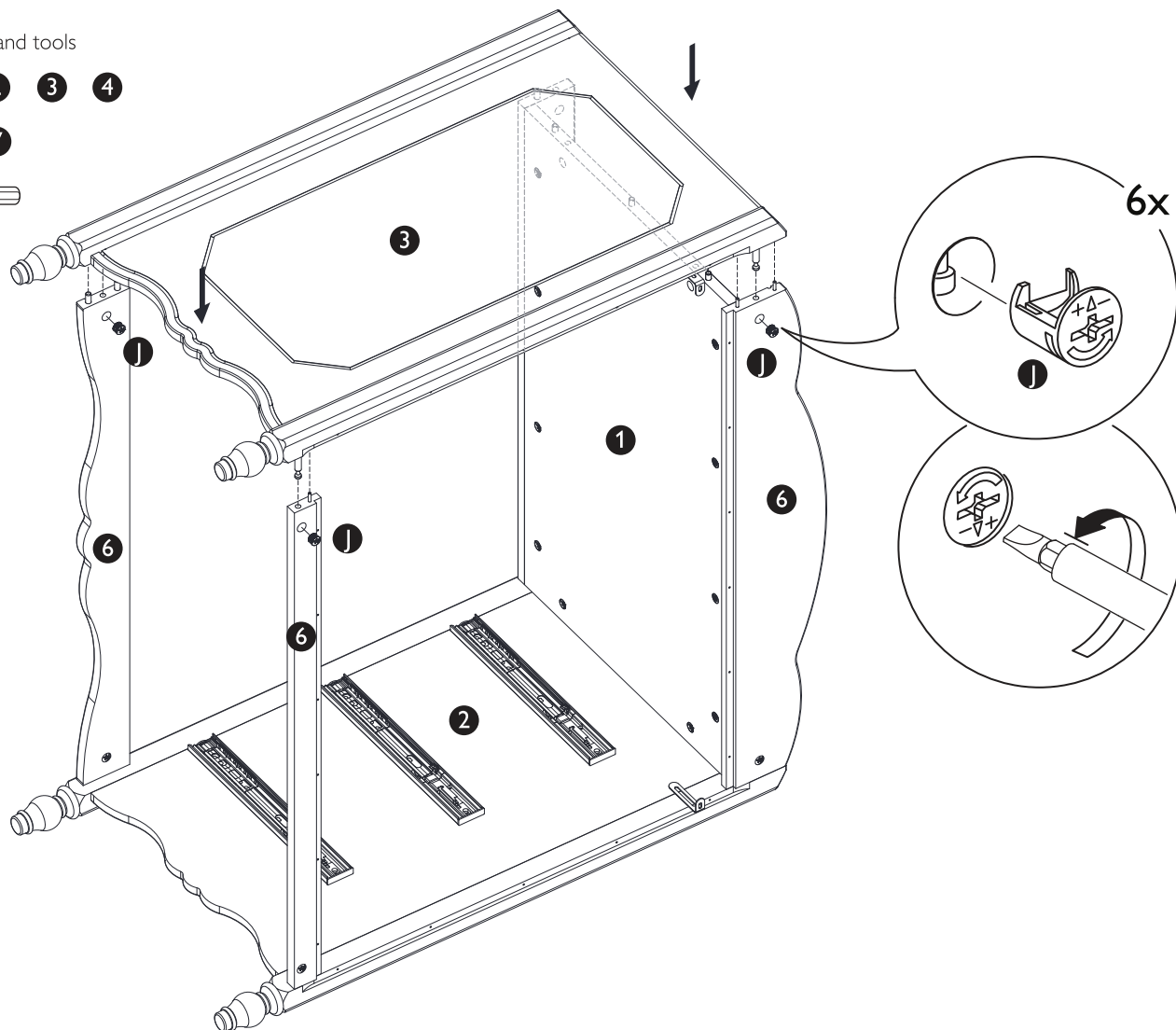
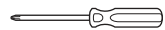

Product assembly

Cloud dresser

Step 7

Parts, fittings and tools

- B
- 2
- 3
- 4
- 6
- 8
- 9

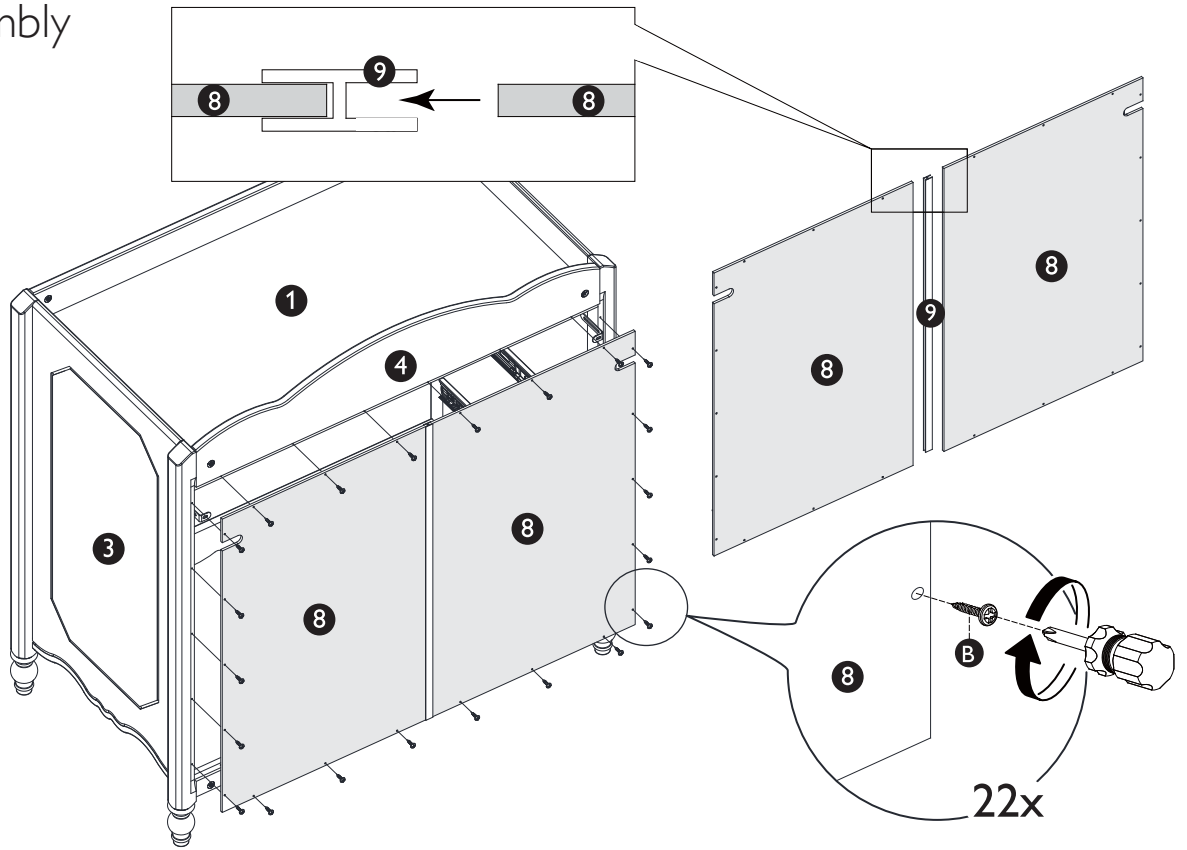
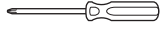

Step 8

Parts, fittings and tools

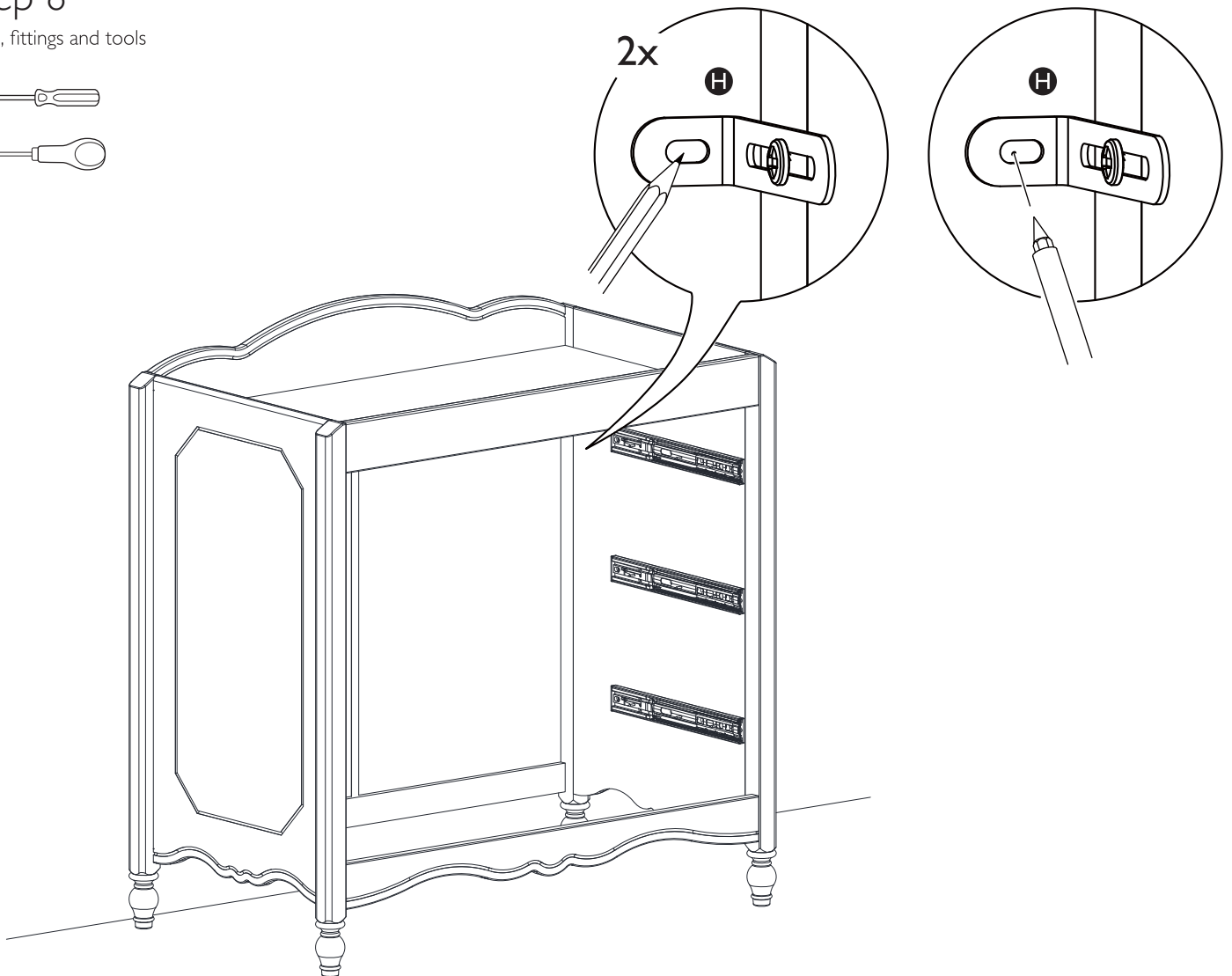
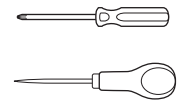

Product assembly

Cloud dresser

Step 9

Parts, fittings and tools

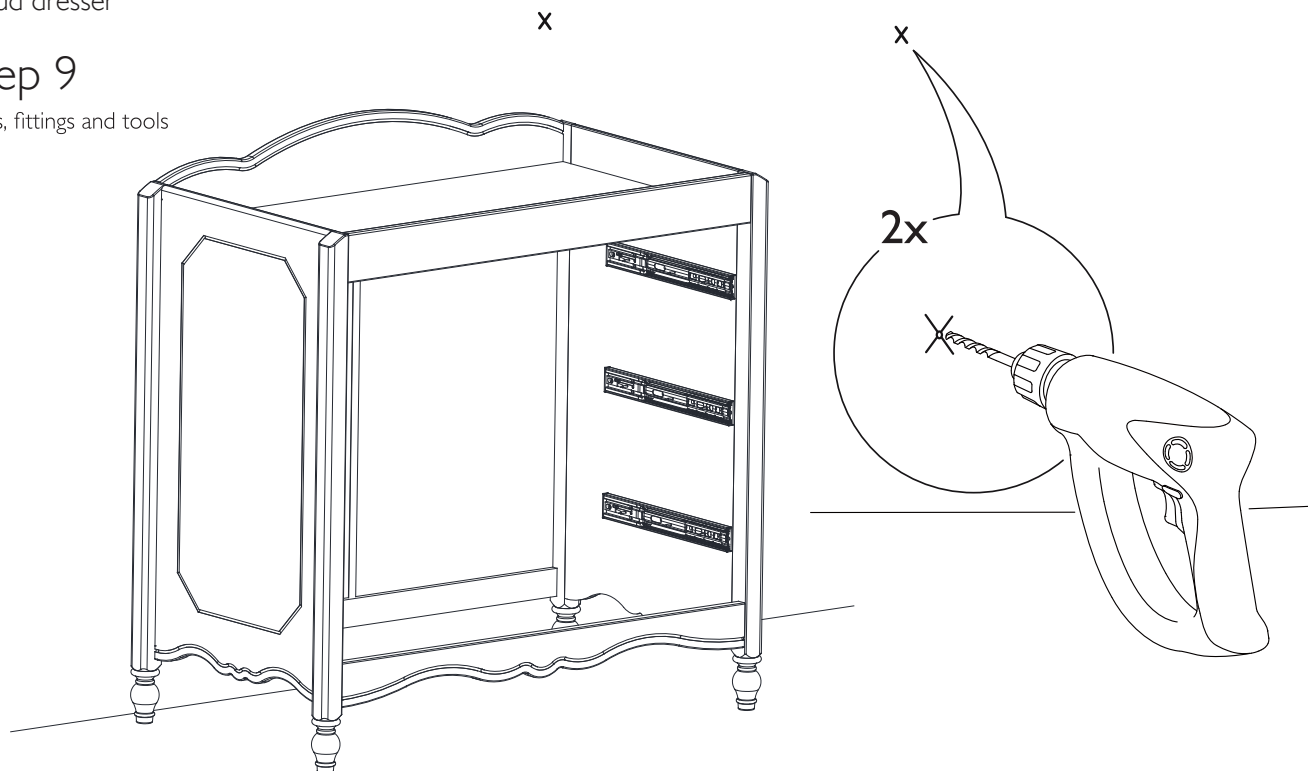

Step 10

Parts, fittings and tools

H

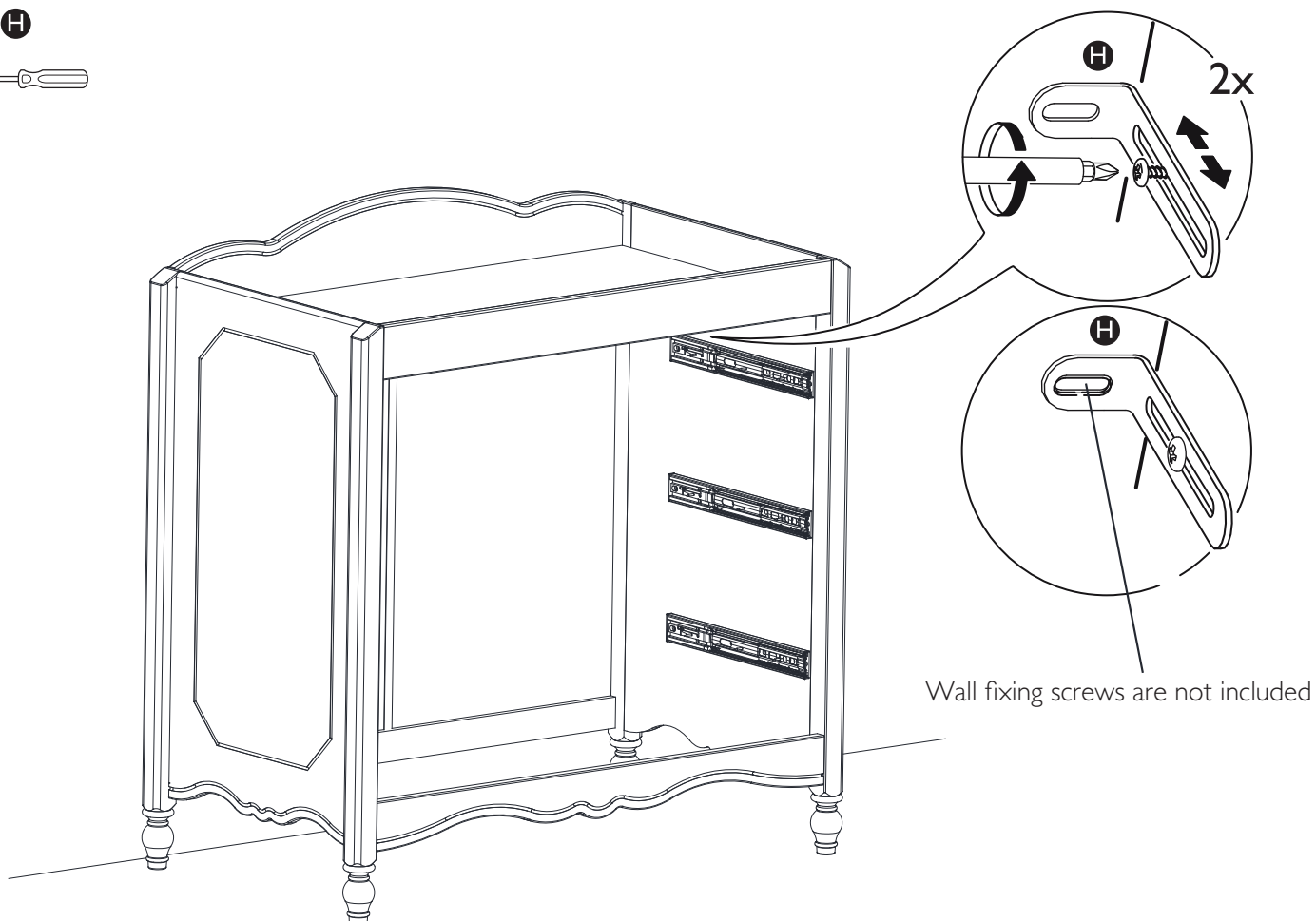
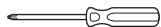

Product assembly

Wall mounting and fixings

⚠ Warning In order to prevent overturning this product must be used with the wall attachment device provided. Wall fixing screws are not included, since different wall materials require different types of screws/ fixings. Please ensure you use the correct screws/fixings for your type of walls and seek professional advice if you are not sure. Installation shall be carried out exactly according to the instructions provided - otherwise a safety risk can occur if incorrectly installed. Failure of the product due to incorrect fixings is the responsibility of the installer.

Important: When drilling into the walls always check that there are no hidden wires or pipes etc.

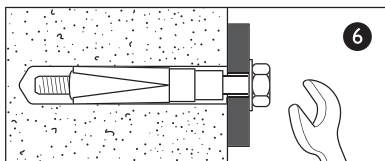
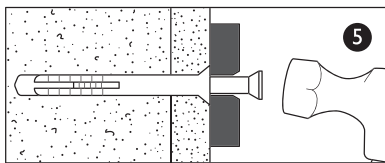
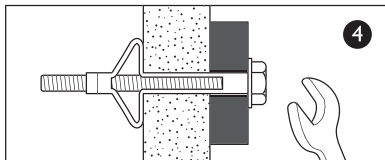
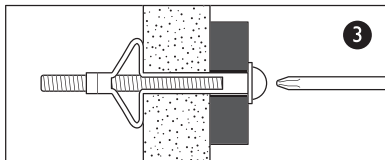
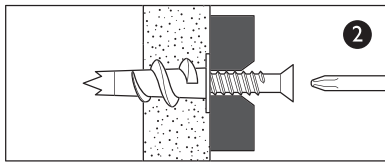
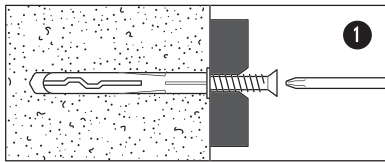

Types of walls

You can use one of the following types of wall plug if your walls are made of brick, breezeblock, concrete, stone or wood.

1. General Purpose wall plug

Generally aerated blocks should not be used to support heavy loads, use a specialist fitting in this case. For light loads, general - purpose wall plugs can be used.

2. Plasterboard wall plug

For use when attaching light loads on to plasterboard partitions.

3. Cavity Fixing wall plug

For use with plasterboard partitions or hollow wooden doors.

4. Cavity Fixing- Heavy Duty wall plug

For use when fitting or supporting heavy loads such as shelving, wall cabinets and coat racks.

5. Hammer Fixing wall plug

For use with walls stuck with plasterboard. The hammer fixing allows it to be fixed to the wall rather than the plasterboard. Always check the fixing is secure to the retaining wall.

6. Shield Anchor wall plug - Heavy loads

For use with heavier loads such as TV and Hi-Fi speakers and satellite dishes etc.

⚠ Care and maintenance

Safety: Periodically check all fittings and wall fixings to ensure they have not come loose and retighten as necessary.

Product assembly

Cloud dresser

Step 11

Parts, fittings and tools

- K** **J** **C** **L**
- 11** **12** **13** **14** **15**

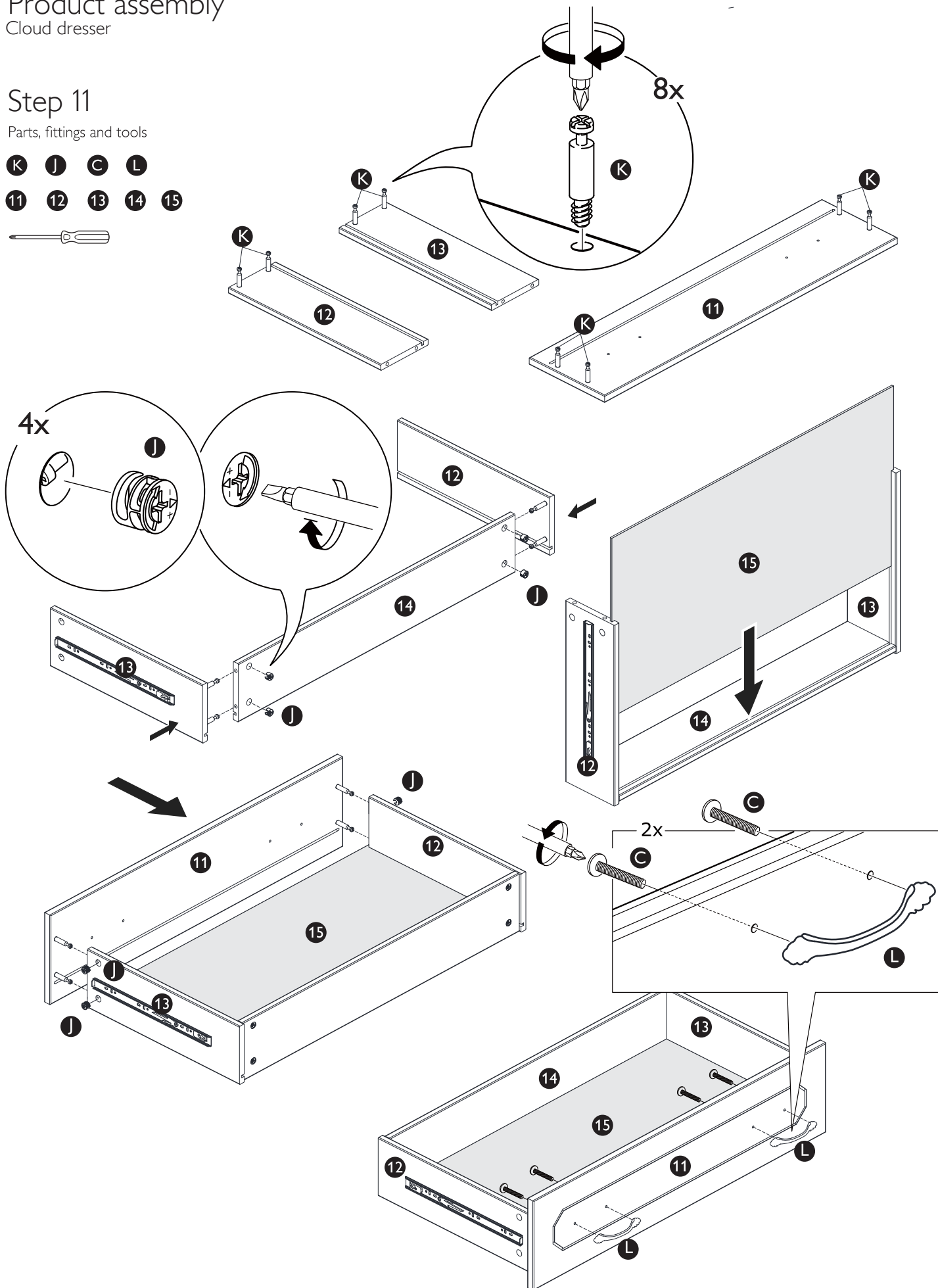
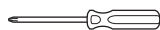

NOTE: Repeat for remaining drawers

Product assembly

Cloud dresser

Step 12

Parts, fittings and tools

11

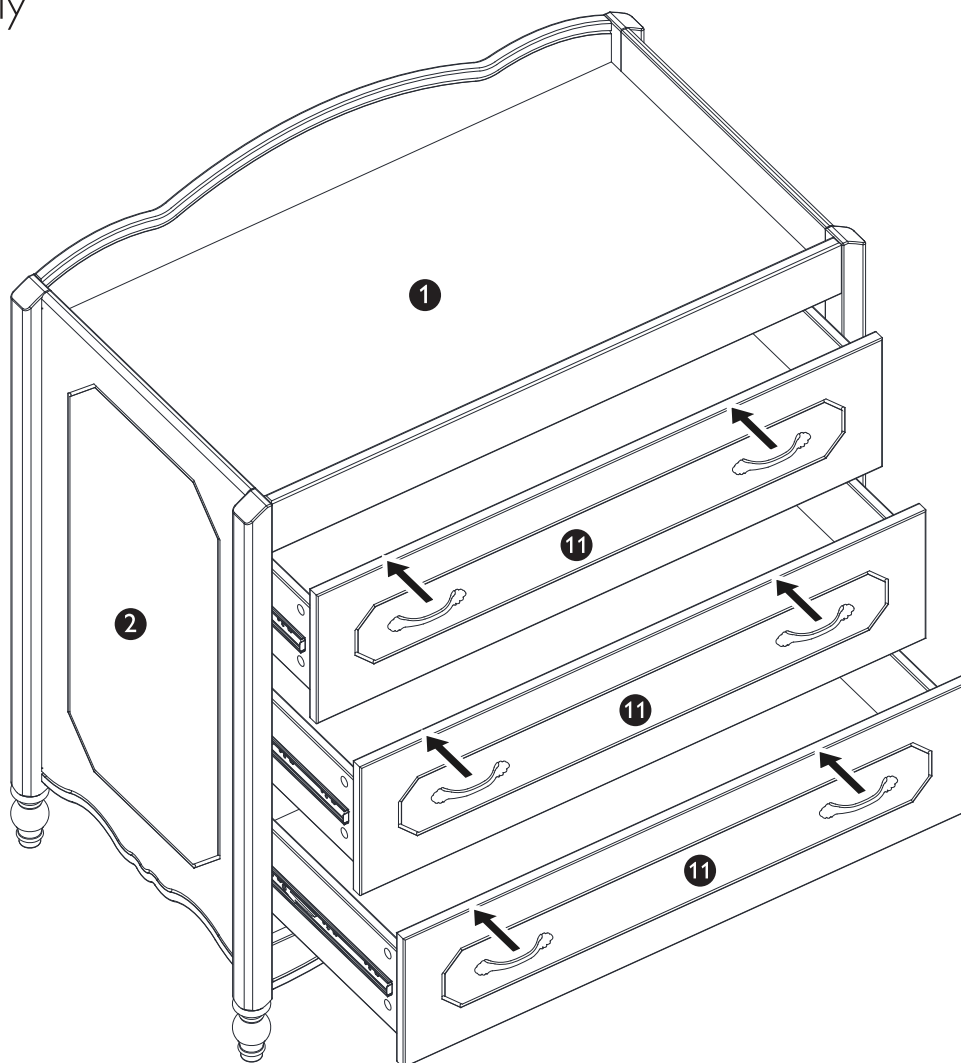

The silver portion of the glide must be pulled to the front of the glide when assembling the drawer into the case.

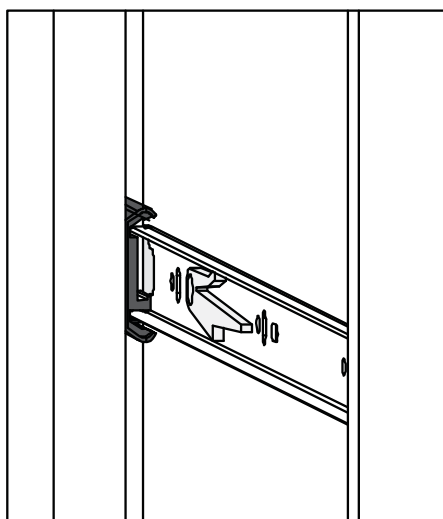
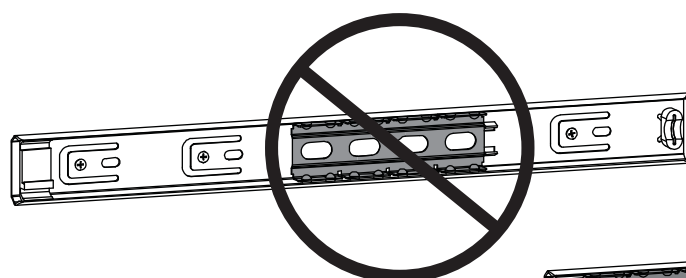

To insert drawer align male runner on drawer to female runner on case and push all the way in.

Care and maintenance

Your furniture may be cleaned by wiping with a damp cloth and drying with a soft clean cloth.

Do not use abrasives, bleach, alcohol or ammonia-based household polishes.

Take care when handling or moving the furniture. Careless handling may cause damage.

Regularly check that all fixings are tightened and that there are no broken or damaged parts.

Safety notes

Warning: Do not leave your child unattended.

Keep children clear during assembly as pack contains small parts which may present a choking hazard.

All assembly fixings should always be tightened properly. Care should be taken that no screws are loose because a child could trap parts of their body, or clothing (e.g. strings, necklaces, ribbons, dummies, etc) which could pose a risk of strangulation.

The changing area is suitable for use up to 12 months old or 11kg in weight.

When using a changing mat, ensure the changing mat does not compromise the elective height of the changer barriers.

Be aware of the risks of open fires and other such sources of strong heat, such as electric bar fires, gas fires, etc. in the near vicinity of the dresser.

Ensure that the wall strap is used to securely attach the dresser to the wall to prevent tipping.

Do not use the changing unit if any of the parts are broken, torn or missing.

Any additional or replacement parts can only be obtained from the manufacturer or the distributor.

Care guide

Care and maintenance

Wood furniture

Wood displays different grain patterns depending on which way they are cut – for example, the ‘medullary ray’ which can appear on oak furniture is a mark of good quality timber – these are just characteristics of the natural beauty of the wood. Some furniture is also deliberately aged and rustic.

Wood veneers also allow a distinctive pattern to be created on some surfaces, such as tabletops and drawer fronts by the way slivers are arranged.

All timber and veneer surfaces will change colour and mellow over time. New furniture will initially vary in shade from items that have been previously purchased.

How to care for your wood furniture

Furniture with a hard lacquer, wax polish or painted surface should be dusted with a dry cloth.

Waxed furniture will need to be given a coat of beeswax a couple of times a year to help maintain its lustre.

Spray polishes are best avoided as they contain silicones which may spoil the furniture’s surface when building up over time.

Make sure all surfaces are protected from heat and liquids by mats and coasters. Wipe up spills immediately and ensure that a mat or pad is placed under paper if you are writing.

Our furniture will endure most temperatures in the home, but it is best to avoid placing furniture next to heat sources such as radiators or fires. Be particularly careful with solid wood as the lack of humidity caused by home heating can cause damage such as warping.

Safety instructions

Never drag furniture when moving it, always lift it.

Periodically check all fixings to ensure none have come loose and retighten when necessary.

Please take care when handling or moving the furniture as careless handling may cause damage or injury.

Furniture can be dangerous if incorrectly installed. Assembly should be carried out by a competent person. No liability will be accepted for damage or injury caused by incorrectly installed or assembled furniture.

Retain these instructions for future reference.

Your feedback is very important to us and we would love to hear your comments on your new furniture. Please visit our website to leave a review.
Thank you.