

Wiring connections	Spring (A)	Spring (B)	Spring (C)	Spring (D)	Spring (E)	Spring (F)
3V battery compartment (1)	black			red		
3V battery compartment (2)		black		red		
ON/OFF switch			red		red	
Basketball sensor				red	red	
Gearbox of basketball stand		black	red			
Gearbox of Action Dino	black		red			
Bubble blower	black		red			
Motor module with spring pole		black	red			
Metal wire					silver	silver
Wand				red		

Insert x 4 AA batteries and switch on the ON/OFF switch, then aim at the basket and shoot! If you make a successful shot, then the Action Dino, bubble blower and the basketball stand will be triggered to move! The bell will also ring at the same time, as if the whole world is celebrating your successful shot! You can also play an alternate game. Take the wand and challenge the metal wire maze. If the wand touches the metal wire, then everything will be triggered to move! This time, their actions do not mean success but failure!



John Lewis Plc  
 171 Victoria Street  
 London  
 SW1E 5NN  
 johnlewis.com



Please retain these instructions for future reference

Made in China

Build your own  
 125 Scientific challenge

Thank you for purchasing this toy. Please read the instructions and warnings carefully before use to ensure safe and satisfactory operation of this product.

### Warnings!

Adult supervision and assistance is required.

This unit is only for use by children aged 8 years and older.

Not suitable for children under age 3 years. Small parts / components – Choking hazard

Read and follow all instructions in the manual before use.

Packaging materials are not toys.

Please remove all packaging and packing tags/wires before giving this toy to your child.

This toy contains small parts and functional sharp points on components. Keep away from children under age 3 years.

7 x AA size batteries are required (not included)

This product contains small ball which may break off and caused a choking hazard. Not suitable for children under 3 years.

Hair entanglement may result if the child's head is too close to the motorized unit of this toy

Instructions for parents are included and have to be observed

Do not aim at eyes and face. Do not use projectiles other than those provided.

Warning! Not suitable for children under 3 years. Small ball - suffocation Hazard.

Warning. Do not use close to the ear! Misuse may cause damage to hearing.

### Warnings!

**Warning! Adult supervision is required to check the wiring and battery polarity prior to final connection to the power supply. Failure to do so may cause overheating. Locking the motor or other moving parts may damage components and may cause overheating."**

### Caution!

Before setting up this unit, please double check and make sure all wiring connections you have made are correct before inserting the batteries and switching on the unit as failure may result in damage to components or the unit.

When experiment is finished, make sure the batteries are disconnected and switch off the unit before you clear away the wires.

Do not apply any components or parts to the unit other than those provided with this kit.

Do not lock the motor or other moving parts. Otherwise it may cause overheating.

The toy is not to be connected to more than recommended number of power supplies.

### Changing the batteries



Requires 7 x AA batteries, not included

To change the batteries, take out the old batteries from the battery compartment, and then replace them with new batteries.

Batteries should be removed and replaced by adults only.

Only use recommended batteries or those of the same or equivalent type.

Do not mix old and new batteries or batteries of different types.

Batteries are to be inserted with the correct polarity.

The supply terminals are not to be short-circuited.

Remove exhausted batteries from item.

Remove batteries if equipment is not used for extended periods of time.

Rechargeable batteries are to be removed from the item before being recharged.

Rechargeable batteries are only to be charged under adult supervision.

Do not attempt to recharge non-rechargeable batteries.

Batteries contain substances that may be harmful to the environment and human health.

Keep out of the reach of children and seek immediate medical help if swallowed.



This symbol indicates that batteries should not be disposed of in the normal household waste but taken to appropriate local recycling facilities, where and when these are available.

Never throw batteries in a fire or attempt to open outer casing.

This product should not be treated as normal household waste and it should be recycled.

John Lewis do not operate instore take back, but as members of the Distributor Take

Back scheme have funded the development and upgrade of recycling facilities across the UK.

Please take it to your nearest collection facility or for further details contact your local council or visit [www.recycle-more.co.uk](http://www.recycle-more.co.uk).

There are 4 basic individual units in this kit, namely Aim and shoot, Bubble science, Action dino and Buzz wire. By changing different circuit connections and combinations, you can establish play sets of diverse function.

To ensure the success of the assembled toy, be sure to read these instructions and review the diagrams thoroughly before starting.

### Practice basic circuit connection

Below is a demonstration of connecting a simple circuit. You can start with this simple circuit as practice before moving to other advanced circuits. First of all, take out the components shown in below diagram from your amazing connection kit. They may be packed in different bags. Then assemble as per the pictures shown below.

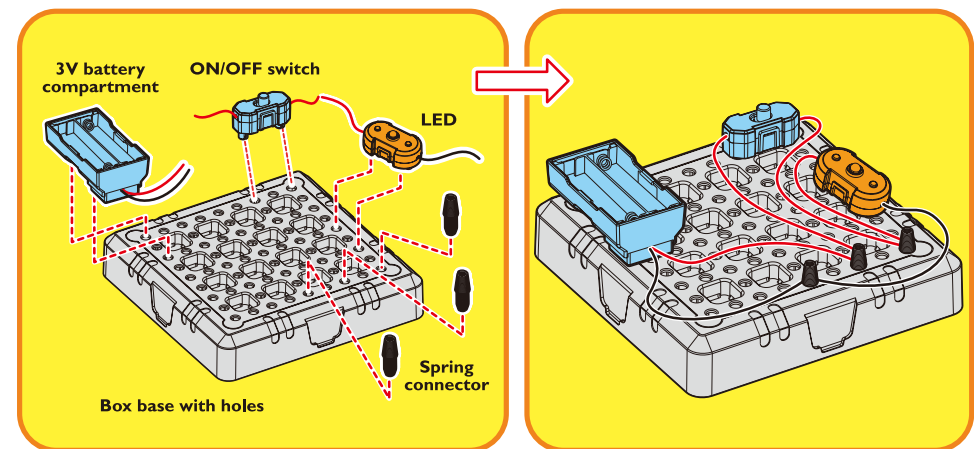

## Basic connection principle

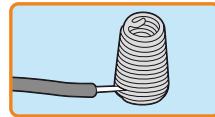
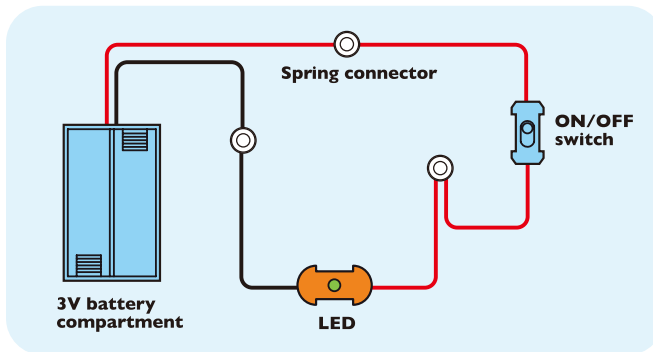

Insert x2 AA size batteries to the 3V battery compartment.  
Turn the switch on.  
The circuit is connected and current can flow in the circuit. Then the LED will light up!

## I. Aim and shoot

### Parts list

Description	Quantity
01 1.5V battery compartment	1pc
02 ON/OFF switch	1pc
03 Spring connector	4pcs (1 spare)
04 Box base with holes	1pc
05 LED	1pc
06 Gearbox	1pc
07 Gearbox cap	1pc
08 Mini-Basketball	1pc
09 Basketball board	1pc
10 Basketball basket	1pc
11 Basketball base	1pc
12 Catapult body	1pc
13 Catapult sling	1pc
14 Basketball sensor	1pc
15 Sticker	1pc

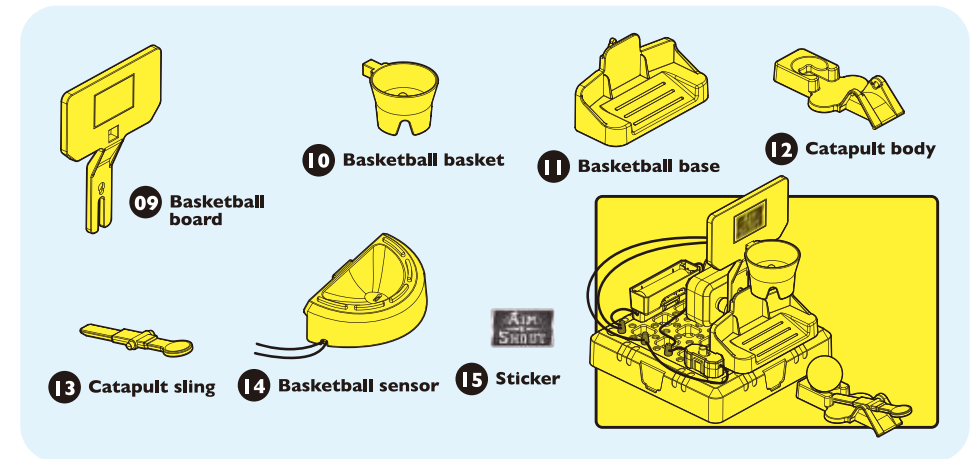
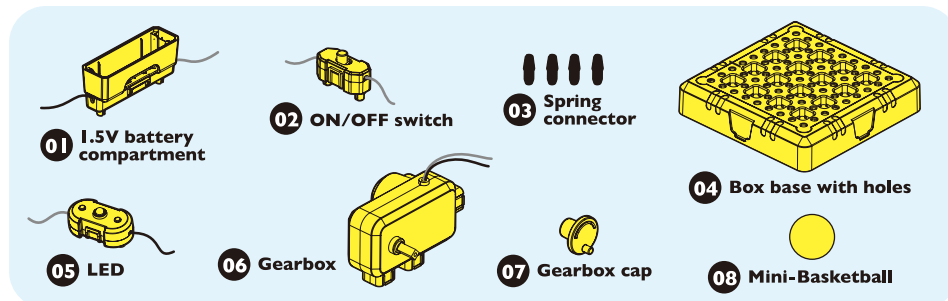

## Assembly instructions

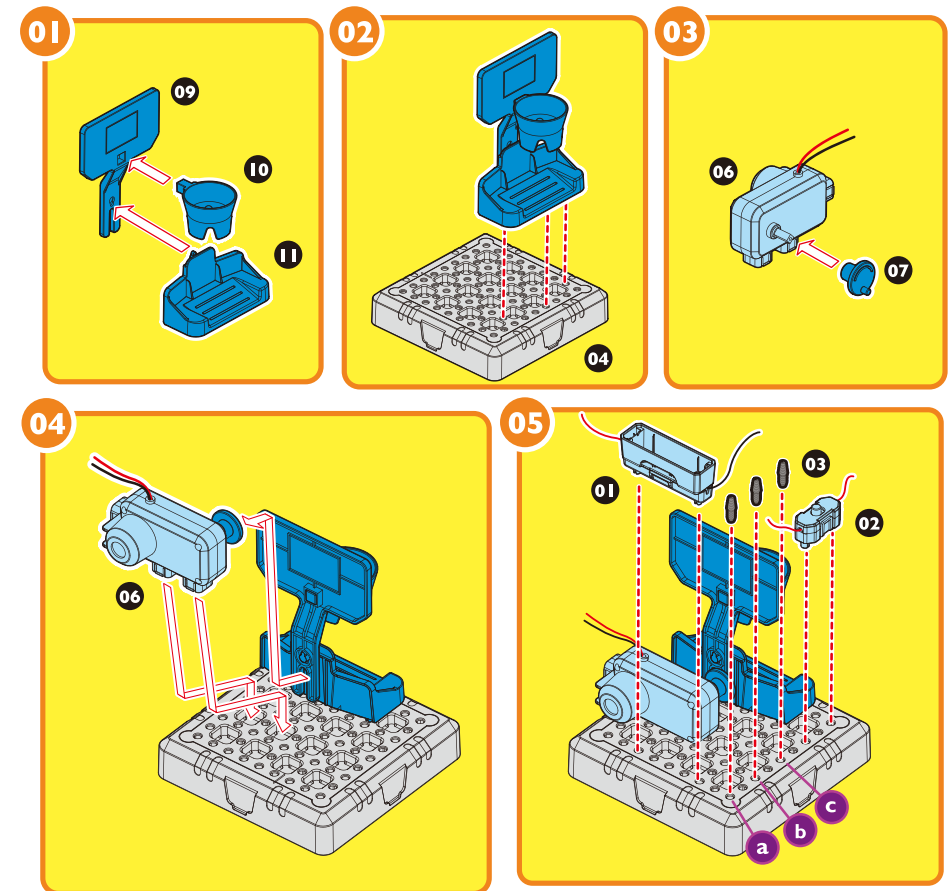

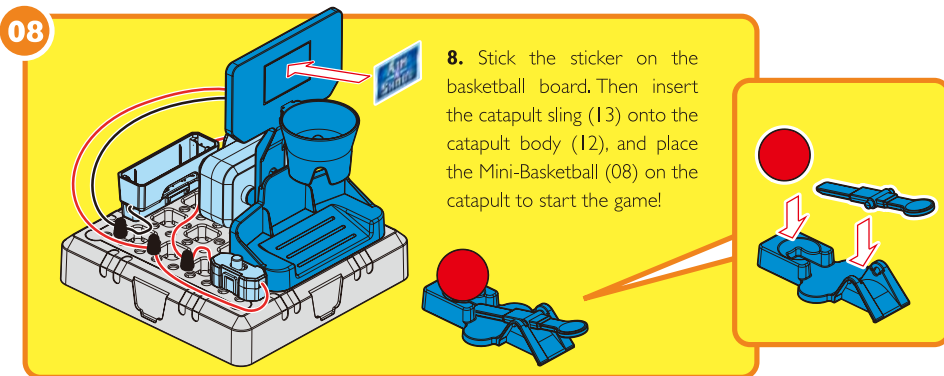
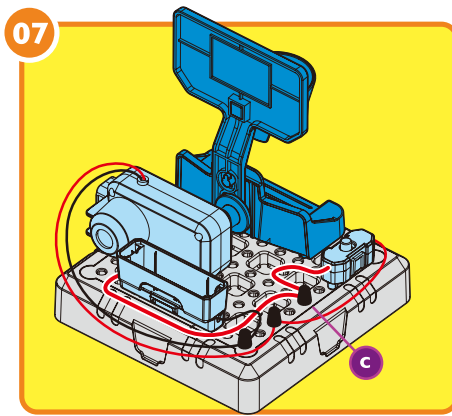
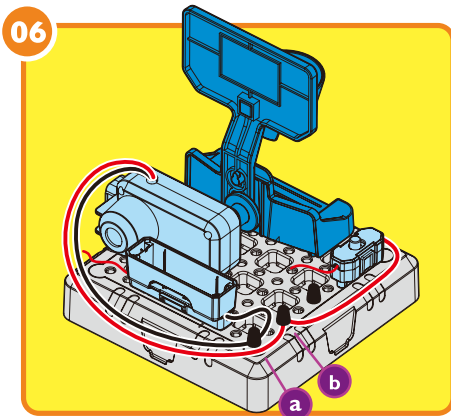

### Basic connection principle

Wiring connections	Spring (a)	Spring (b)	Spring (c)
1.5V battery compartment (01)	black		red
ON/OFF switch (02)		red	red
Gearbox (06)	black	red	

### How to play

Insert x1 AA size battery to the 1.5V battery compartment. Turn the switch on. The assembled basketball stand will start moving from side to side. To play you need to firstly select the desired distance between the basketball stand and the catapult. Then aim at the basketball basket by tapping the catapult sling with your finger. Try to get the ball into the basket. This fun challenge requires skill as well as luck to make a successful shot! So test yourself and give it your best shot!

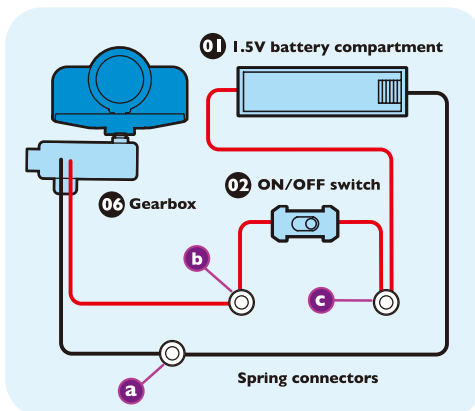

## 2. Bubble science

### Parts List

Description	Quantity
01 3V Battery compartment	1pc
02 ON/OFF switch	1pc
03 Spring connector	3pcs
04 Box base with holes	1pc
05 Connecting bridge	2pcs
06 Blower module	1pc
07 Spinning unit	1pc
08 Blower cover	1pc
09 Bubble plate	1pc
10 Bubble solution container	1pc

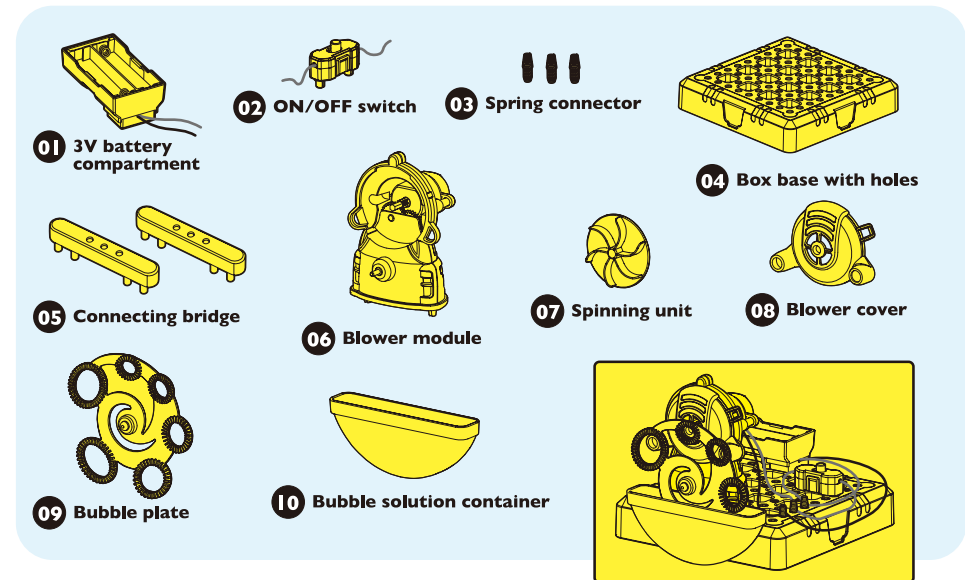

### Assembly instructions

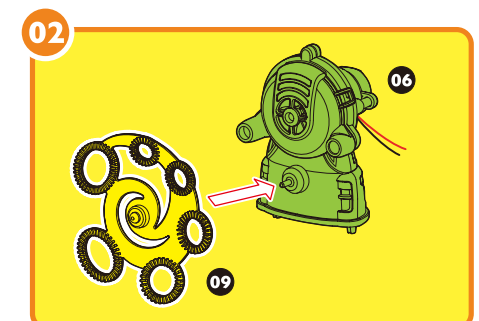
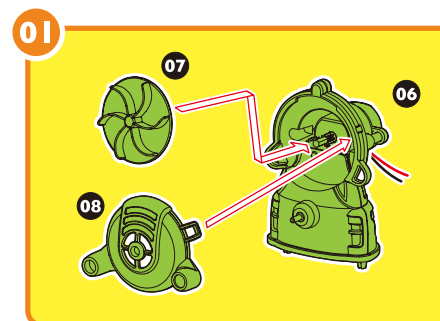

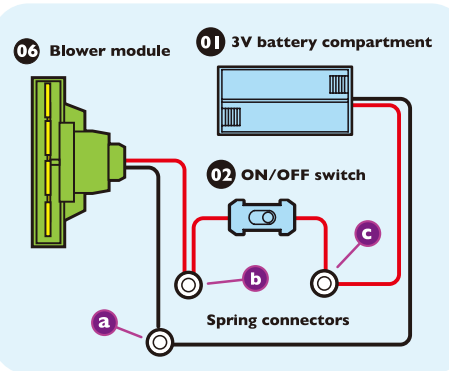
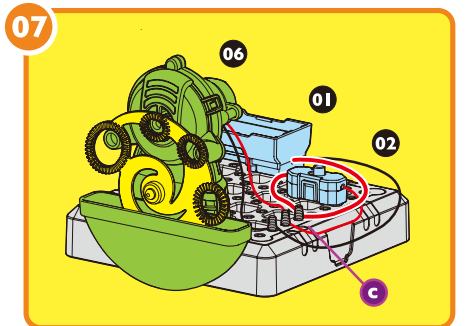
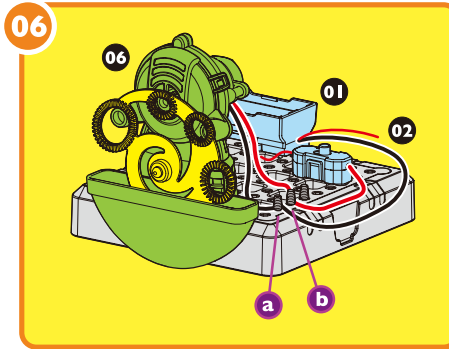
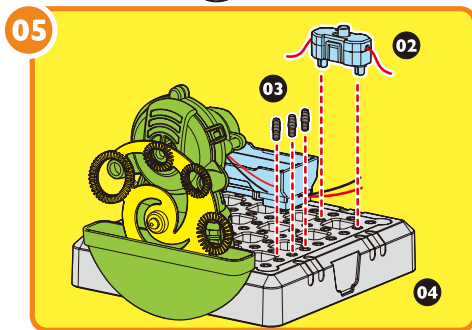
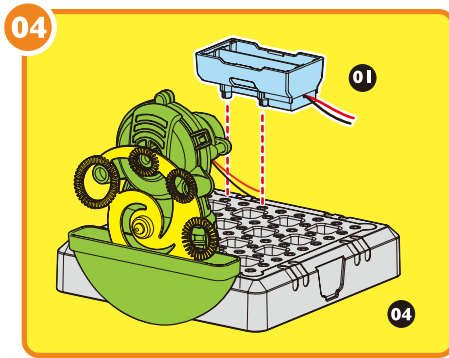
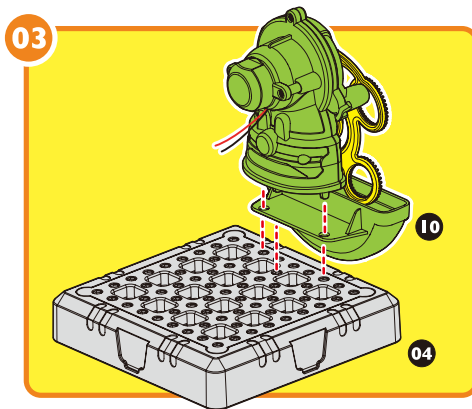

**Basic Connection Principle**

Wiring connections	Spring (a)	Spring (b)	Spring (c)
3V battery compartment (01)	black		red
ON/OFF switch (02)		red	red
Gearbox (06)	black	red	

**How to play**

Place bubble solution (not included) into bubble solution container:  
 Insert to the 3V battery compartment.  
 Turn the switch ON. The bubble plate will start to spin and the blower will blow out bubbles. You will see beautiful bubbles shooting out in a continuous bubble stream!

**3. Action dino**

**Parts List**

Description	Quantity
01 3V battery compartment	1pc
02 ON/OFF switch	1pc
03 Spring connector	4pcs (1 spare)
04 Box base with holes	1pc
05 Connecting bridge	2pcs
06 Gearbox	1pc
07 Gearbox cap	1pc
08 Action rod	1pc
09 Arm	2pcs
10 Main body (left and right part)	2pcs
11 Jaw	1pc
12 Leg	2pcs
13 Tail (left and right part)	2pcs
14 Connecting joint	7pcs

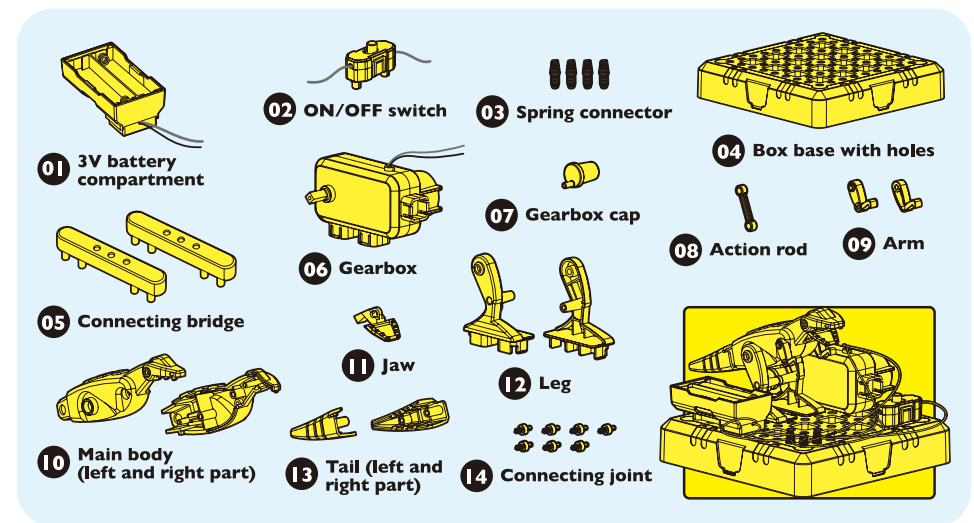

**Assembly instructions**

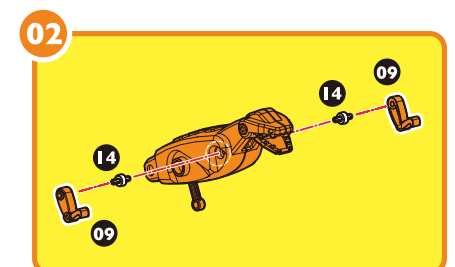
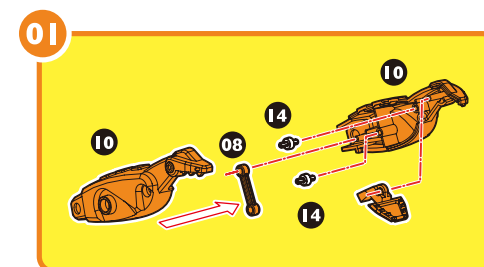

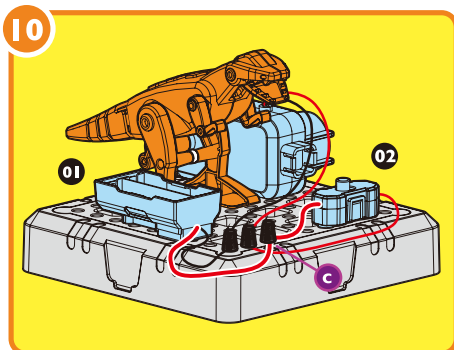
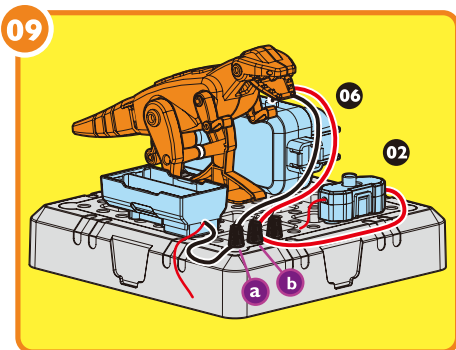
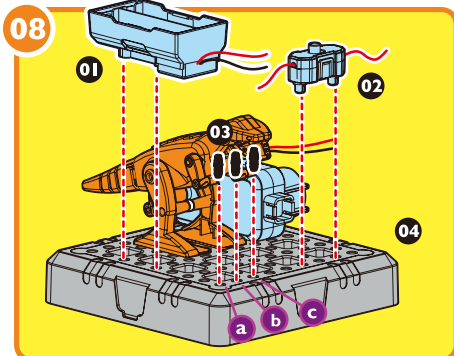
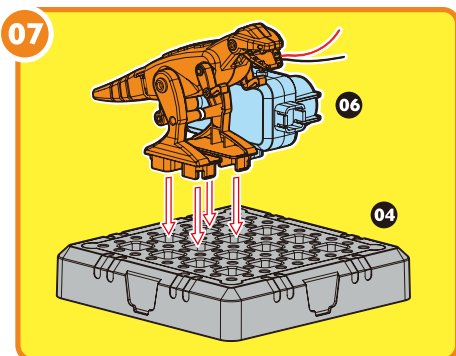
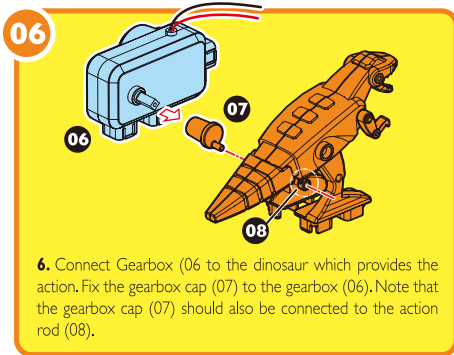
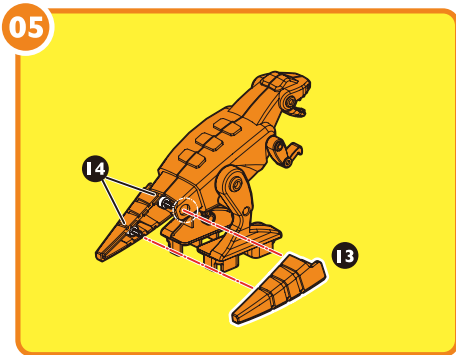
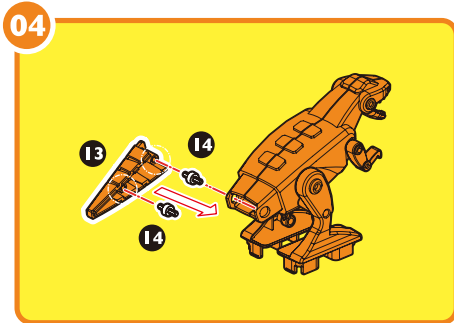
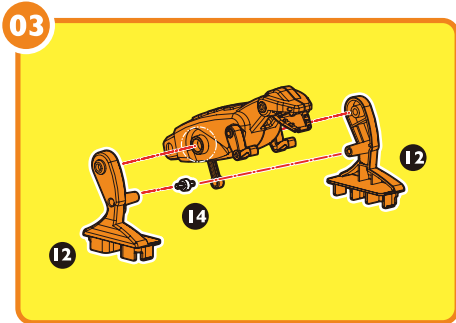

### Basic Connection Principle

Wiring connections	Spring (a)	Spring (b)	Spring (c)
3V battery compartment (01)	black		red
ON/OFF switch (02)		red	red
Gearbox (06)	black	red	

### How to play

Insert x2 AA size batteries to the 3V battery compartment. Turn the switch on. The assembled Action Dino will then start moving

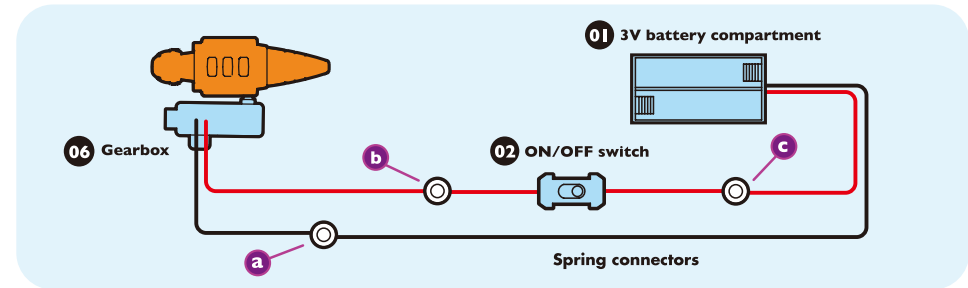

### 4. Buzz wire

#### Parts List

Description	Quantity
01. Bell module	1 pc
02. Motor module	1 pc
03. Box base with holes	1 pc
04. 3V battery compartment	1 pc
05. ON/OFF switch	1 pc
06. Wand	1 pc
07. Spring connector	6pcs (1 spare)
08. Metal wire	1 pc
09. Spring pole	1 pc
10. C-shape plastic lock	1 pc
11. Connecting bridge	2pcs
12. Flying disc	1 pc
13. Colour wheel	1 pc

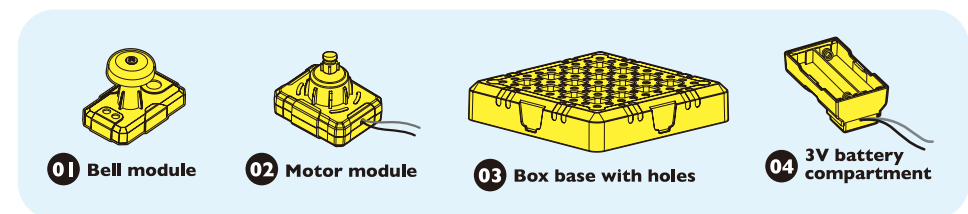

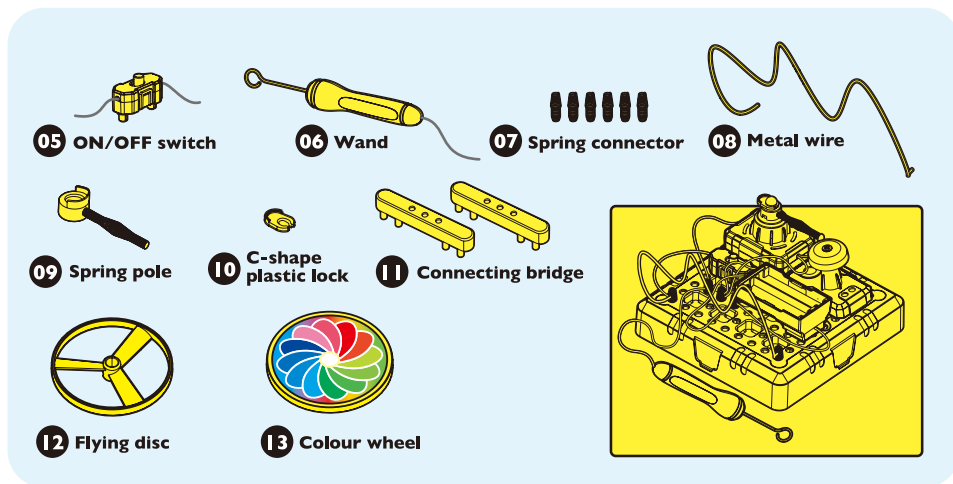

**Assembly instructions**

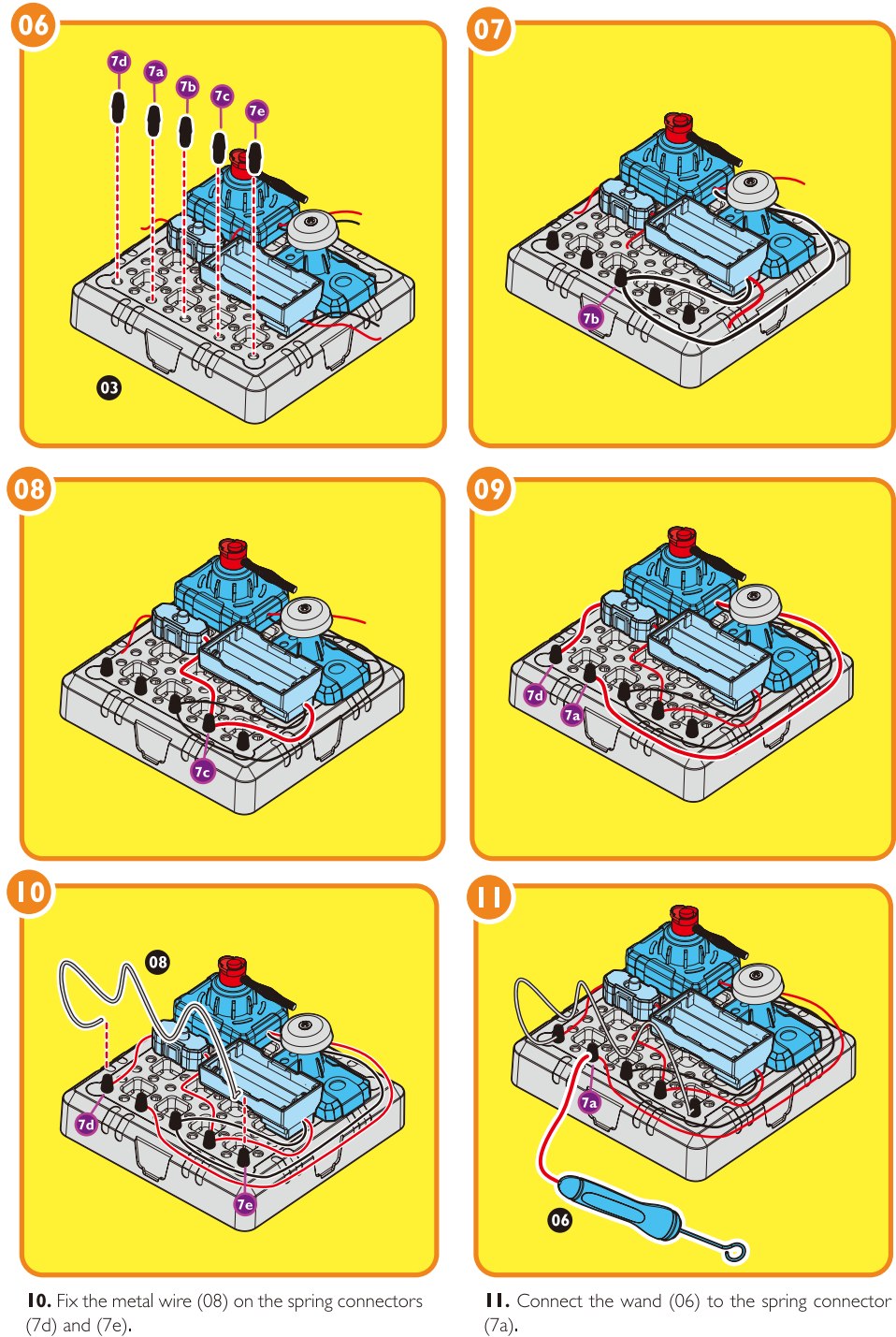
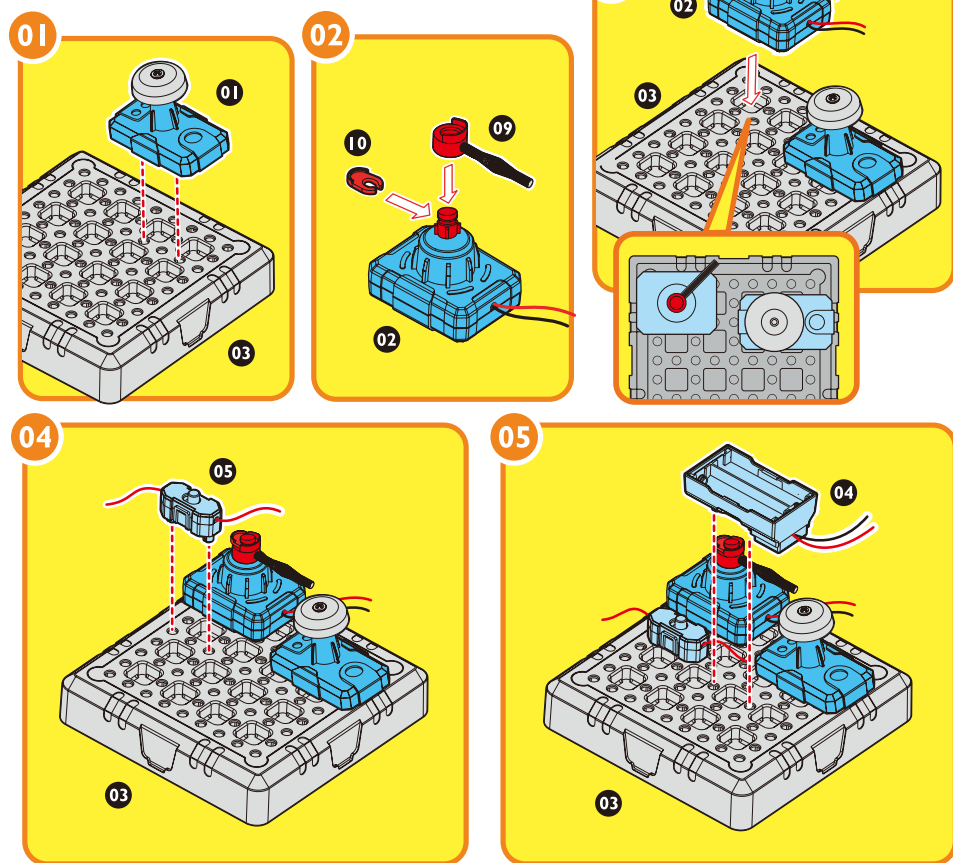

10. Fix the metal wire (08) on the spring connectors (7d) and (7e).

11. Connect the wand (06) to the spring connector (7a).

## Basic Connection Principle

Wiring connections	Spring (7a)	Spring (7b)	Spring (7c)	Spring (7d)	Spring (7e)
3V battery compartment (04)		black	red		
ON/OFF switch (05)			red	red	
Motor Module (02)	red	black			
Metal Wire (08)				silver	silver
Wand (06)	red				

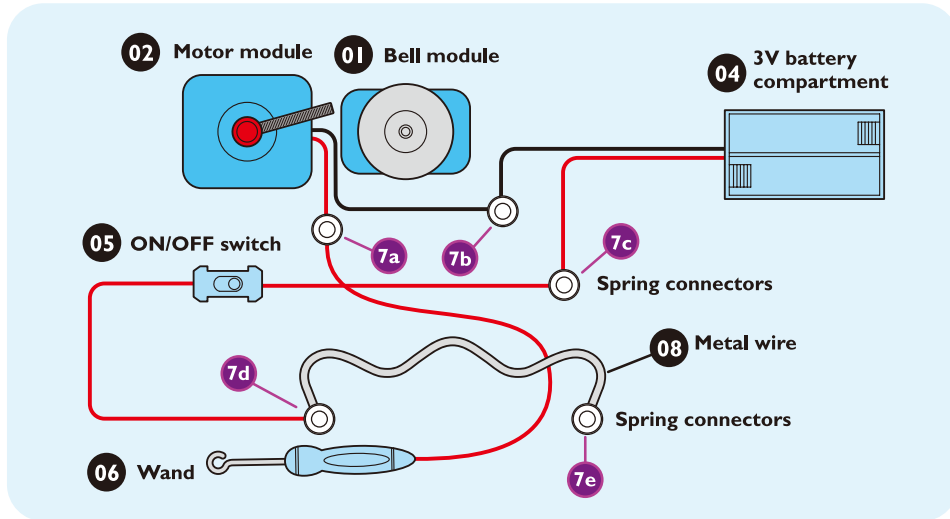

## How to play

Insert x2 AA size batteries to the 3V battery compartment.

Turn the switch on and put the ring of the wand around the metal wire via the open area of the ring. Keep your hand steady and carefully move the ring of the wand through the metal wire. If the ring touches the metal wire, the bell will ring and you lose! Complete the maze to achieve the fastest time against your friends. Bend the metal wire to create different levels of difficulty. Please ensure the switch is off and batteries are removed from battery compartment before bending the metal wire. You can switch to use other functions by replacing the spring pole with flying disc or colour filter.

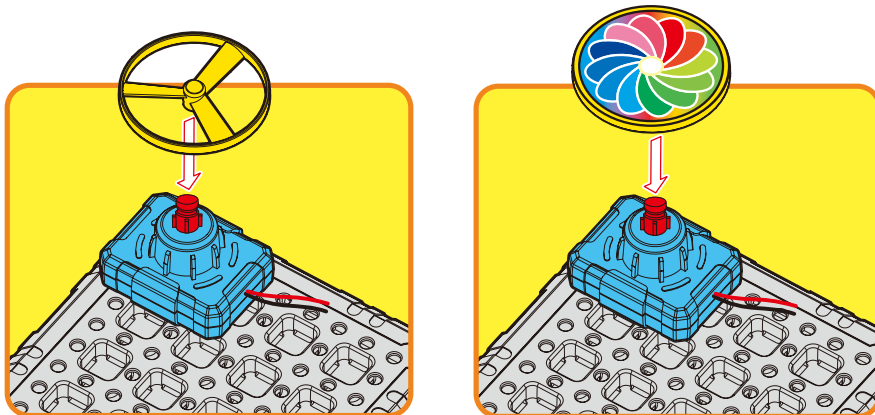

## For more connecting fun

After you have successfully assembled the basic individual units, you can create more exciting interaction with the Aim and shoot, Bubble science, Action dino and Buzz wire together! Here are some basic things to note when using connecting bridges to connect these units together:

If needed, you can adjust the position of the assembled parts on the box base with holes to suit the 2in I or 3in I or 4in I connections. There's no need to keep their position exactly as the basic assembly. You can adjust their positions so long as the circuit connection is correct as the instruction.

There are 3 holes on each connecting bridge. Therefore switch or spring or other things can be installed onto the connecting bridges. This is useful when you find the box base with holes is crowded and hard to find rooms on it. These diagrams are examples:

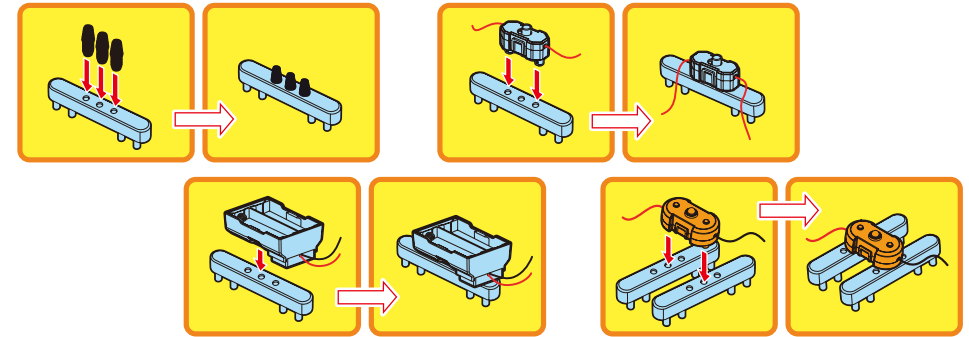

For 3in I and 4in I connections, you can have different connecting arrangements. Below figures are examples. You can decide or modify the arrangement to make your own style! Just make sure that the circuit connection is correct as the instruction.

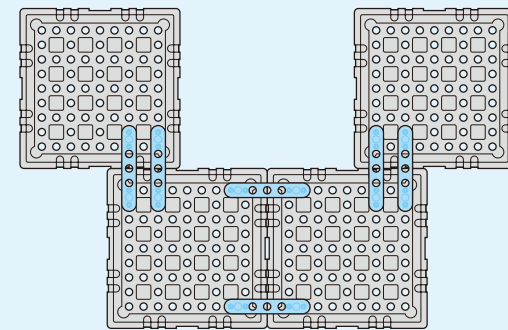
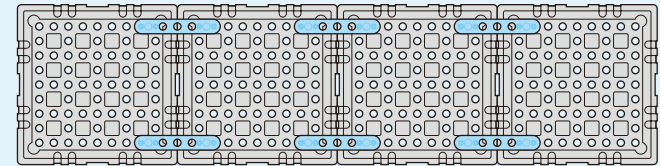



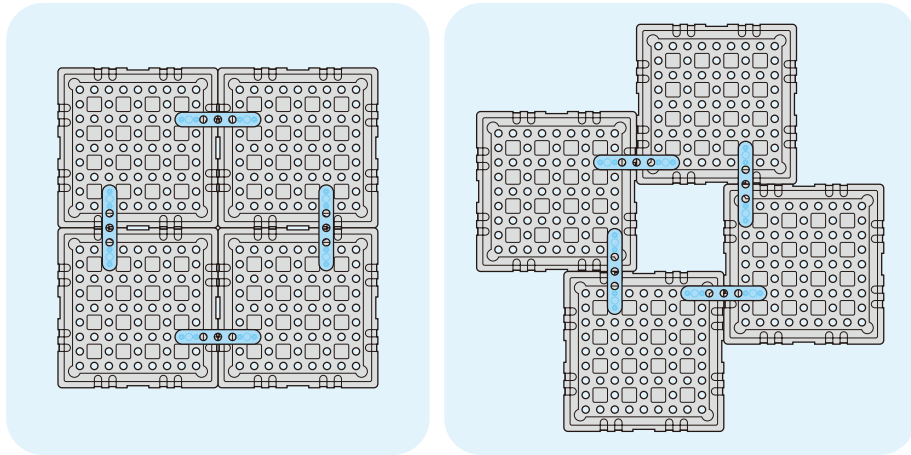

### How to Connect

Put the 2, 3 or 4 box bases together. Use connecting bridges to connect them firmly. Then follow the below connection diagrams to connect!

### Connection symbols

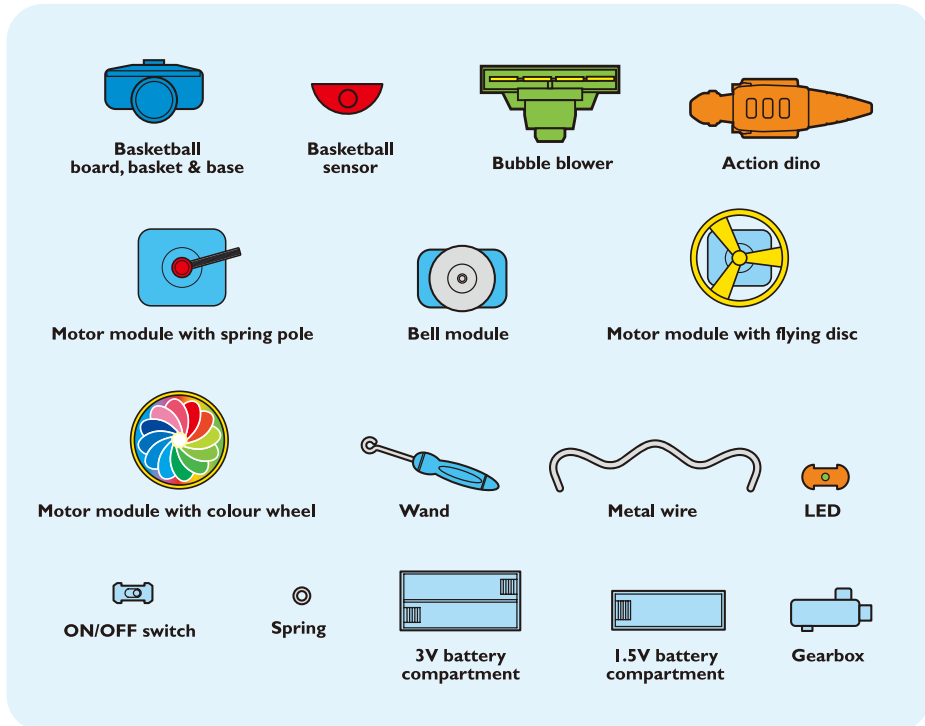

### Connection diagrams

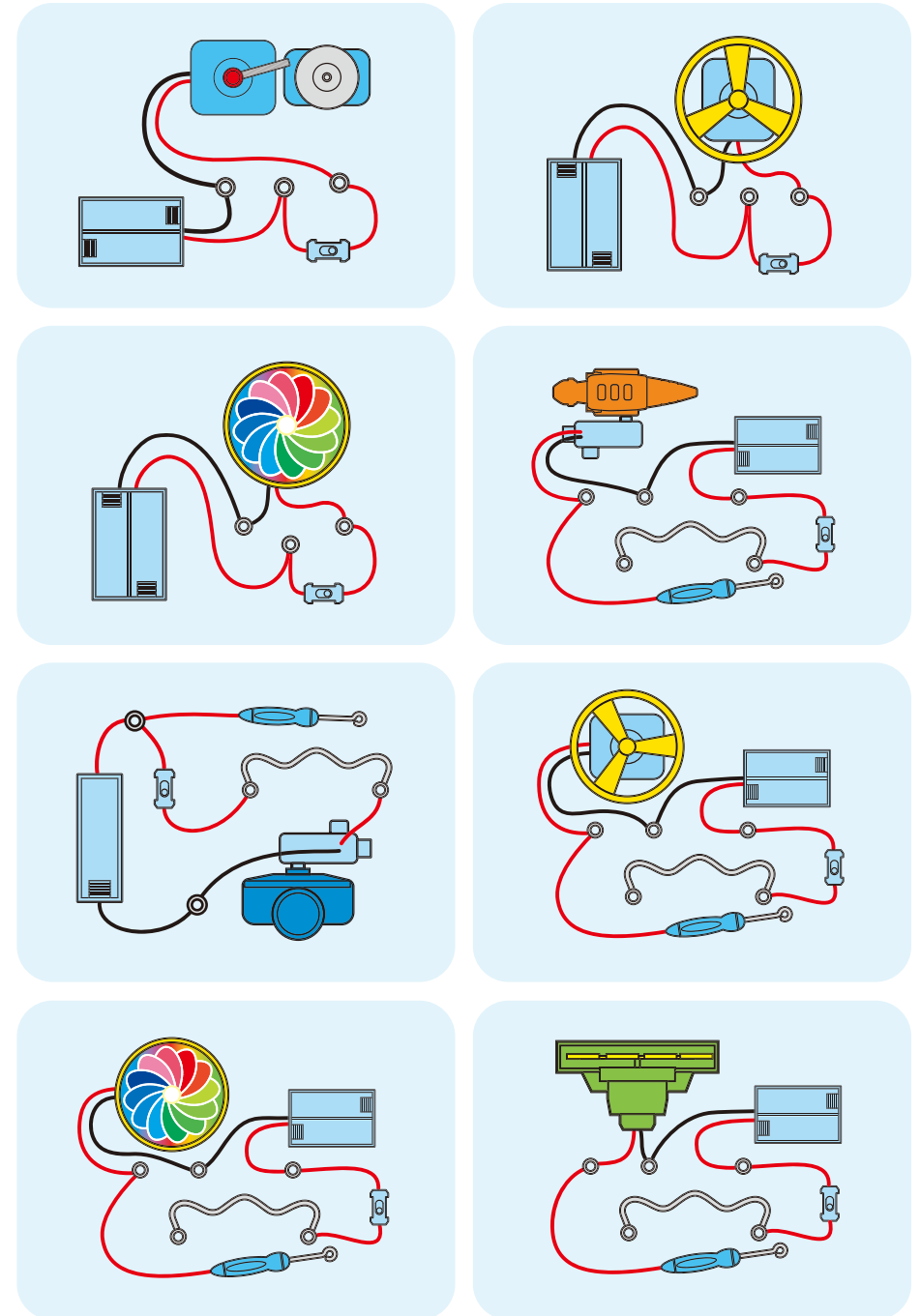

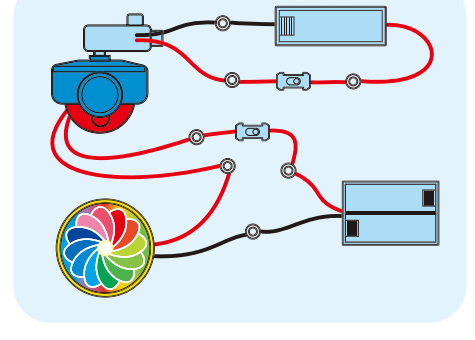
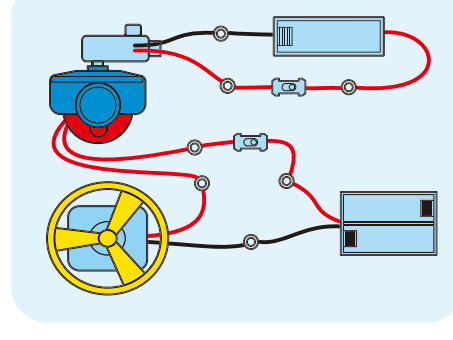
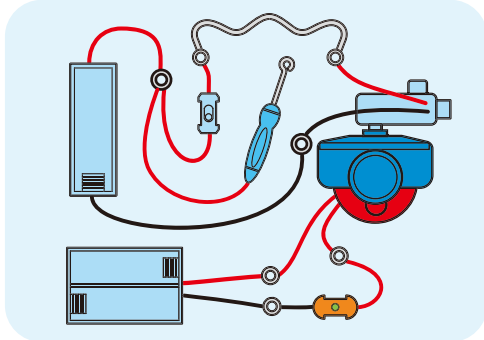
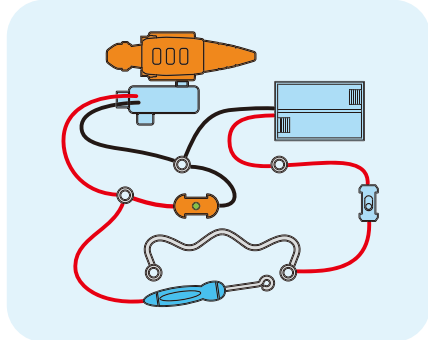
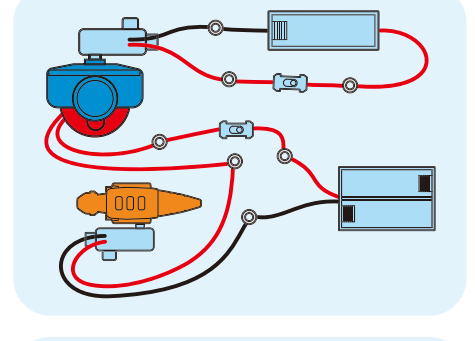
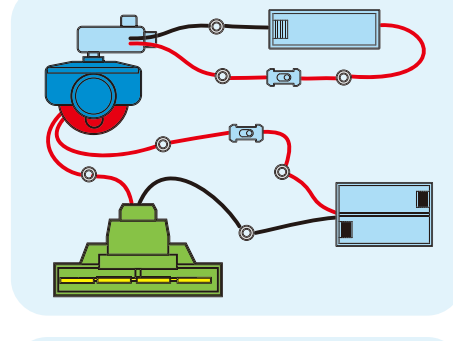
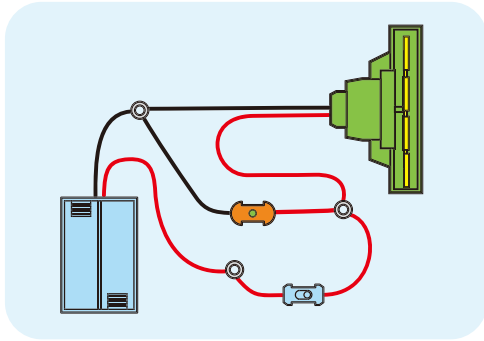
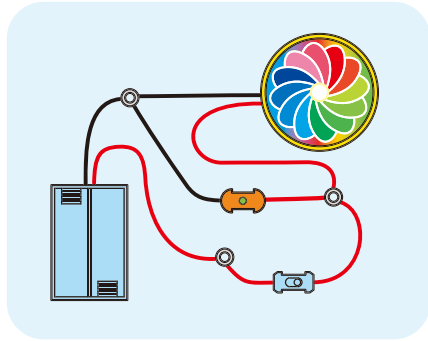
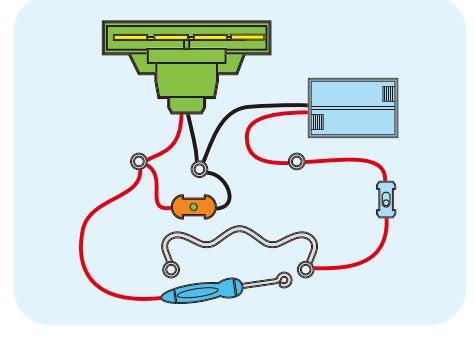
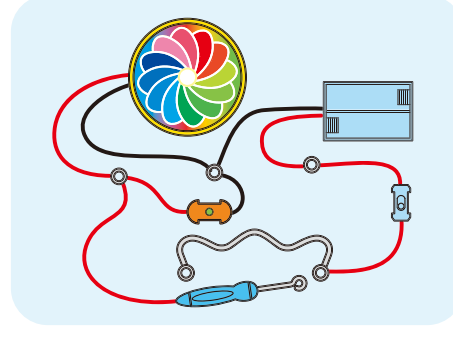
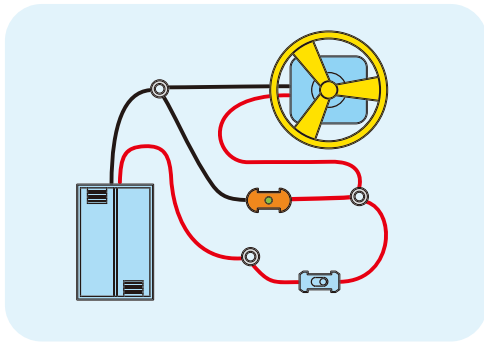
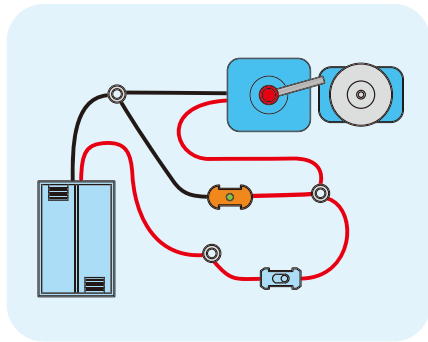
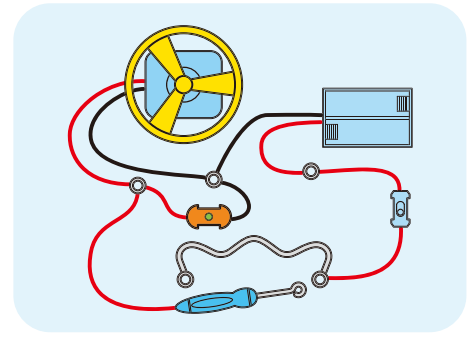
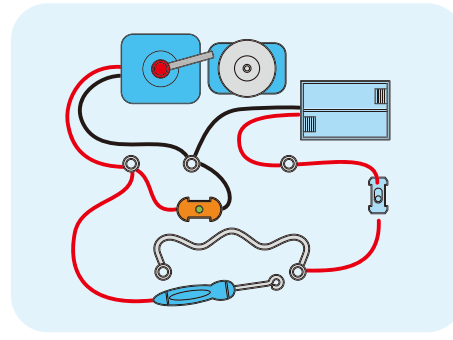
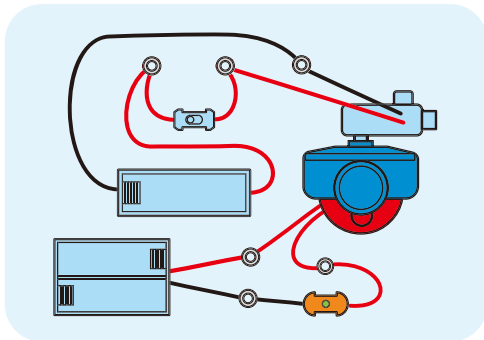
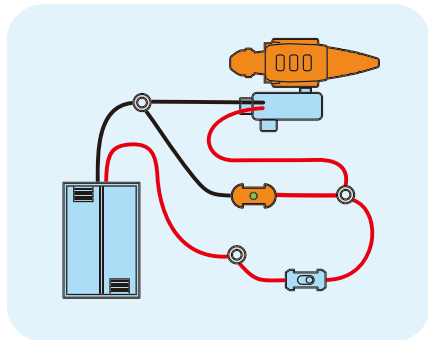

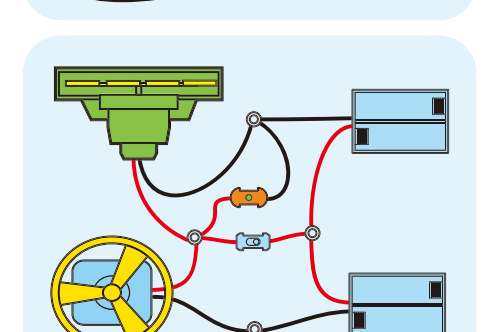
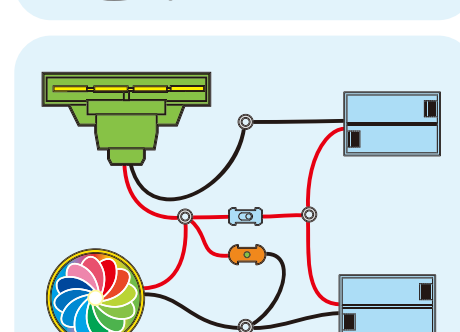
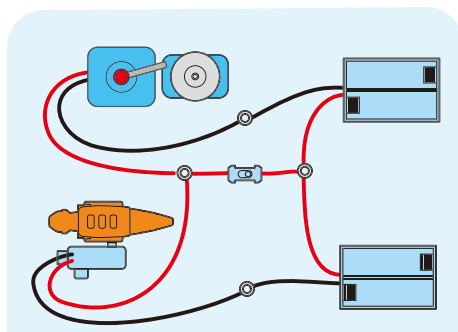
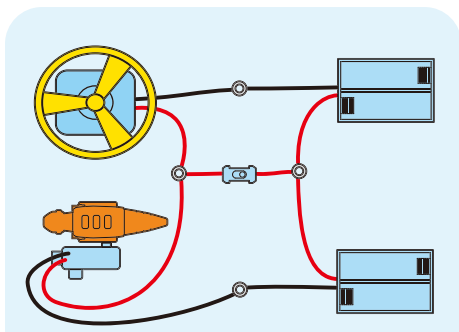
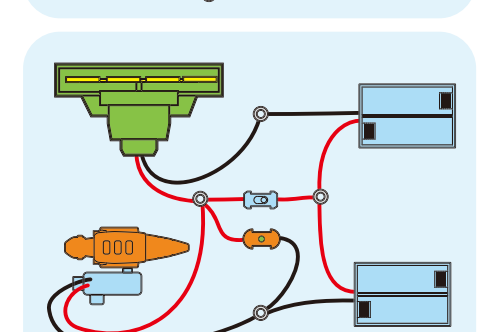
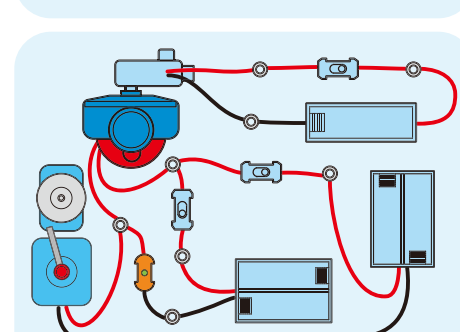
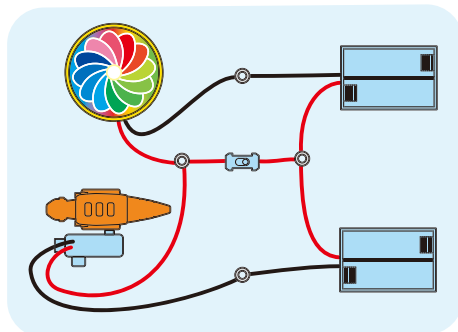
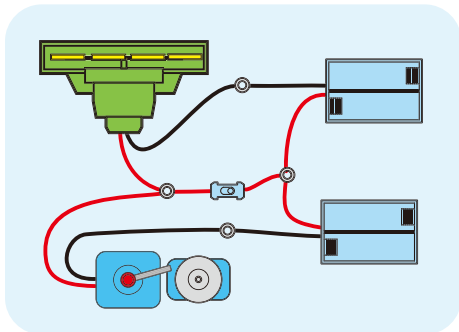
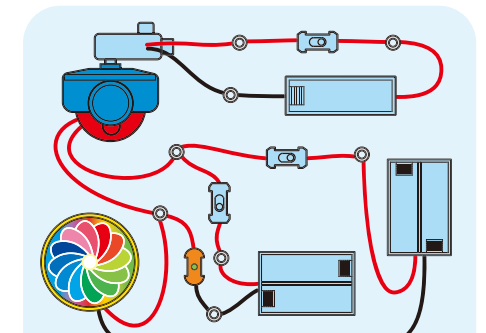
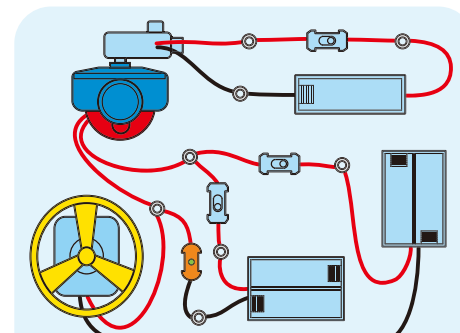
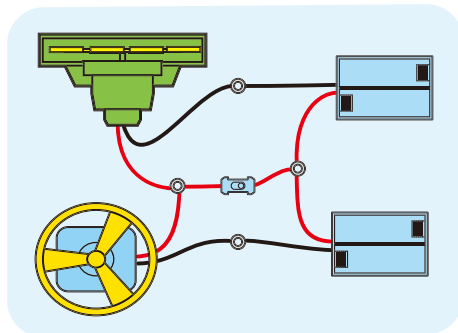
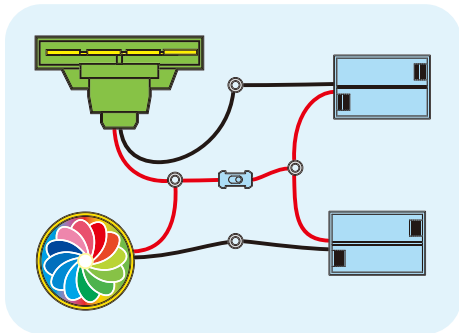
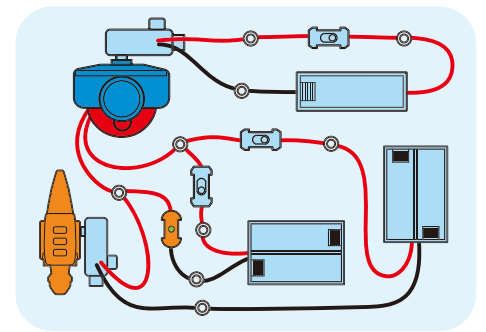
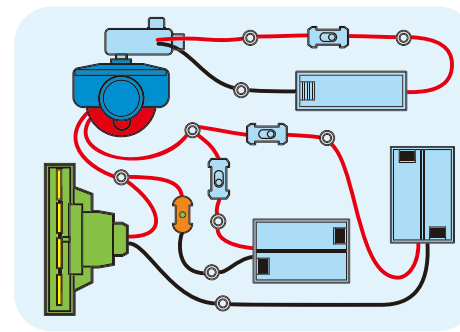
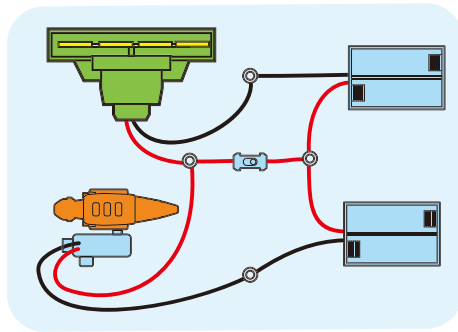
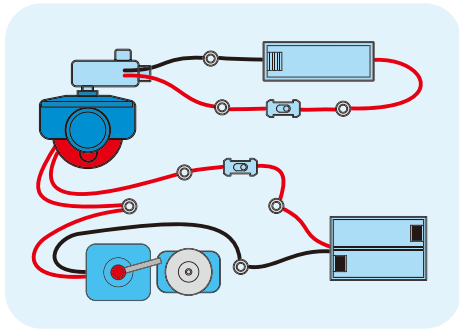

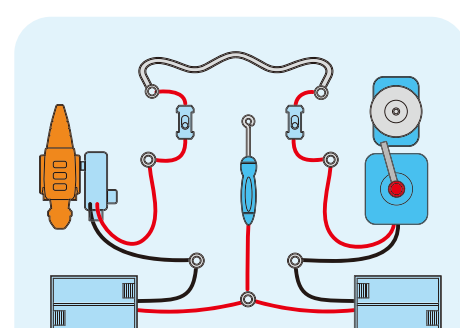
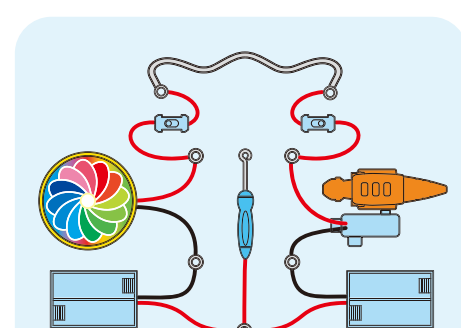
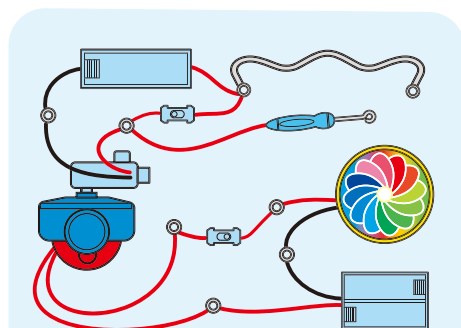
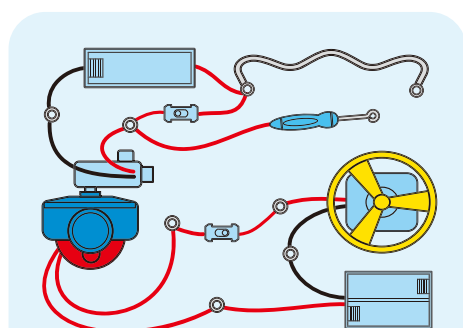
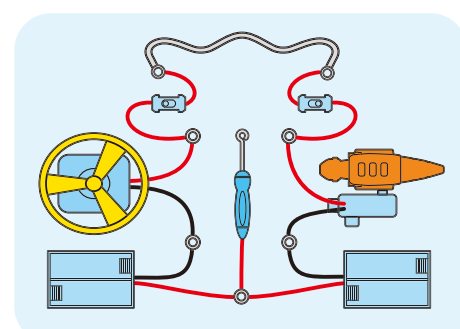
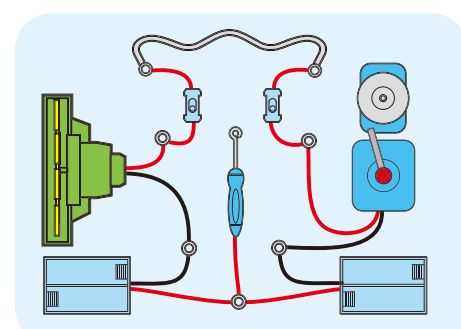
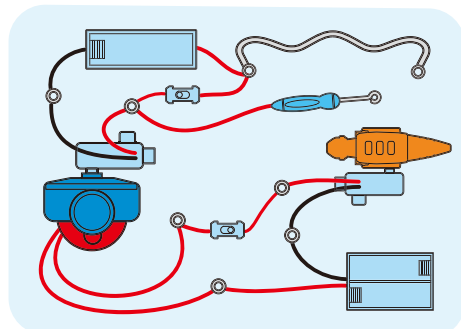
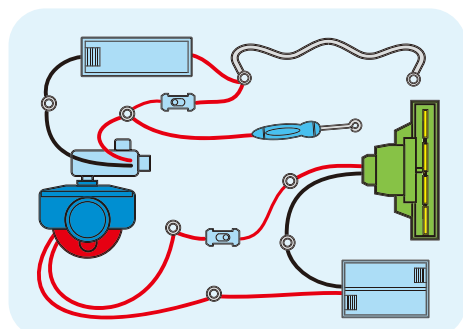
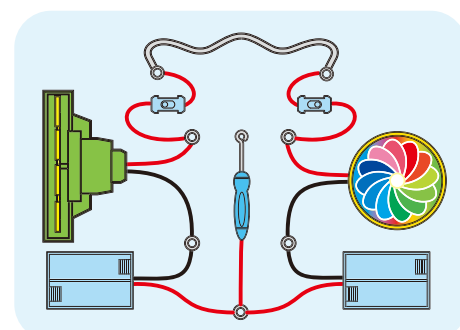
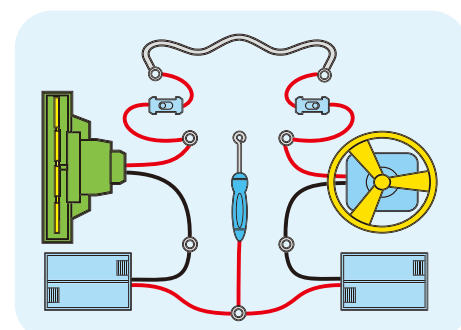
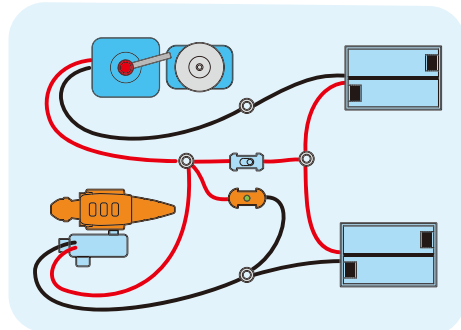
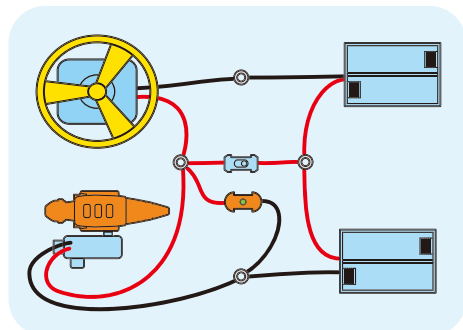
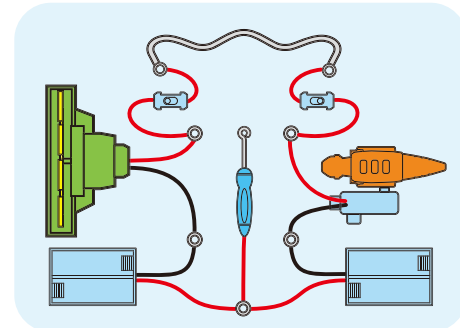
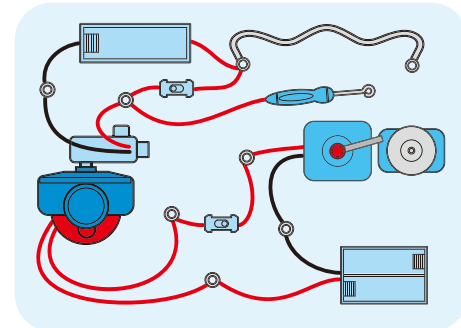
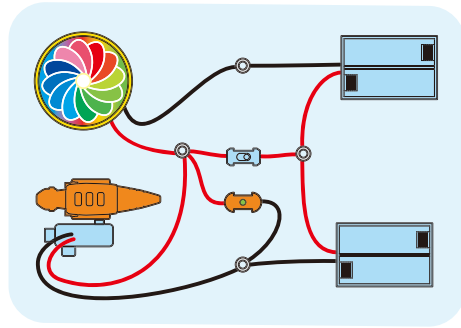
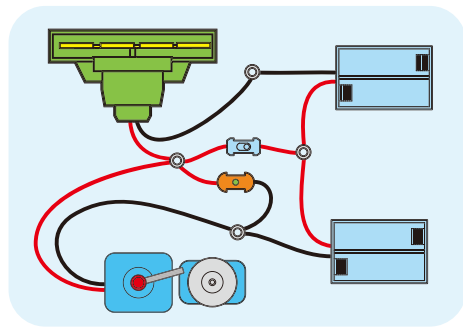

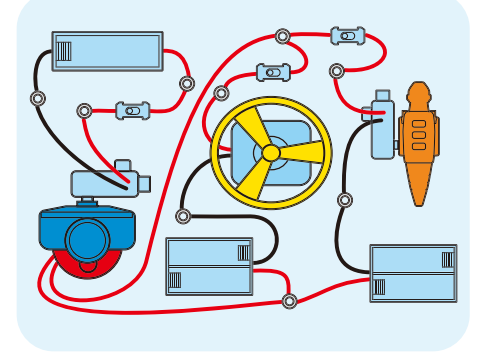
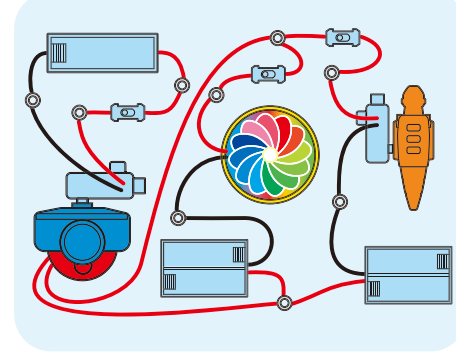
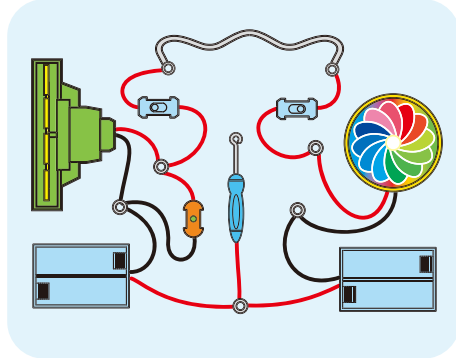
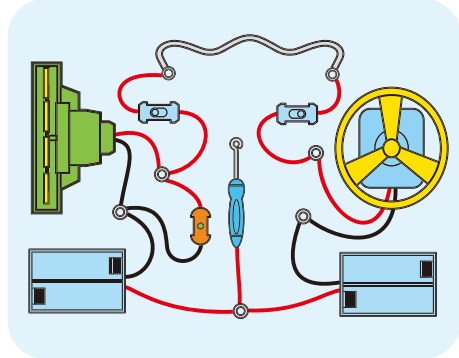
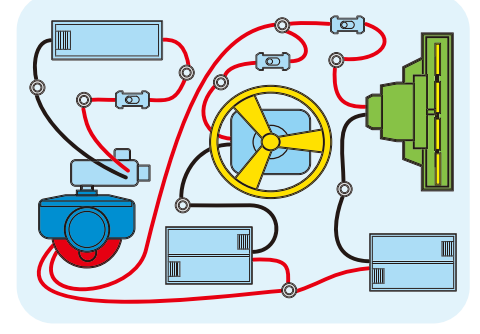
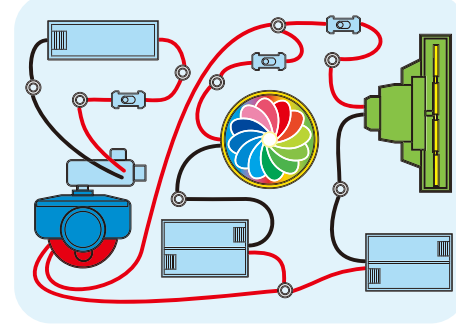
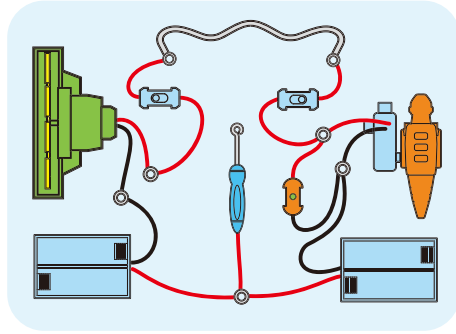
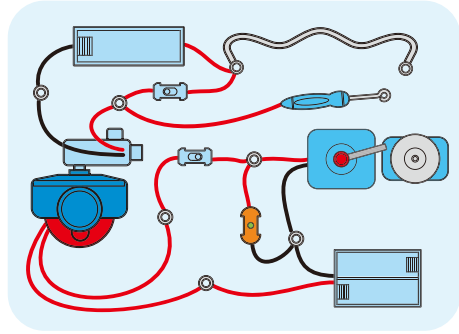
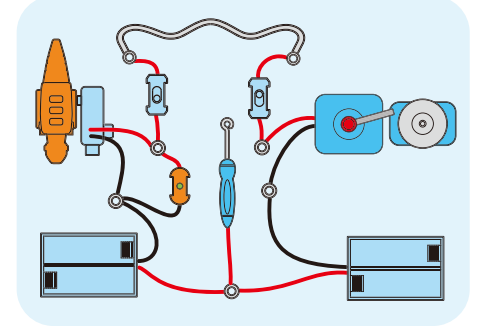
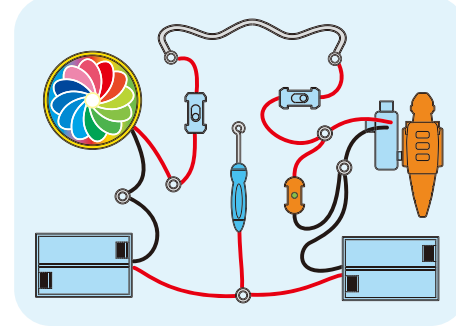
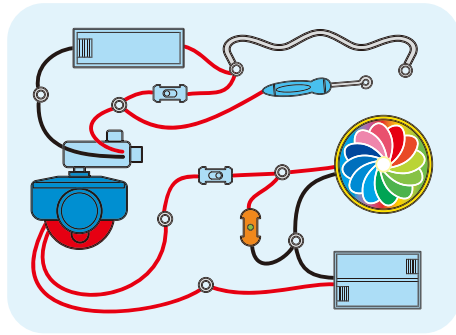
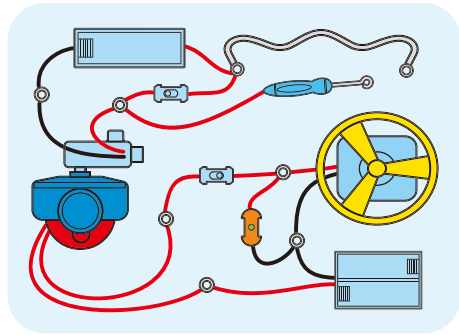
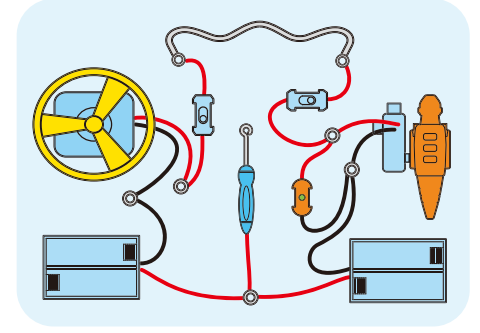
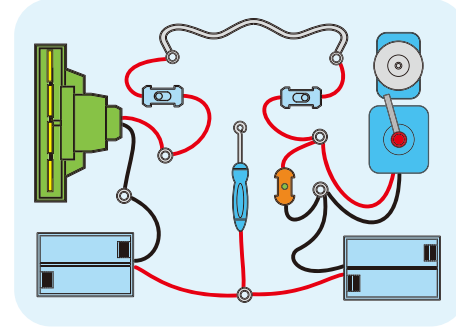
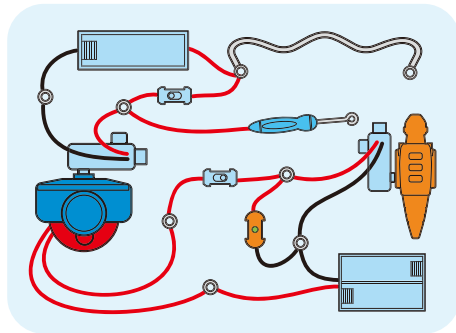
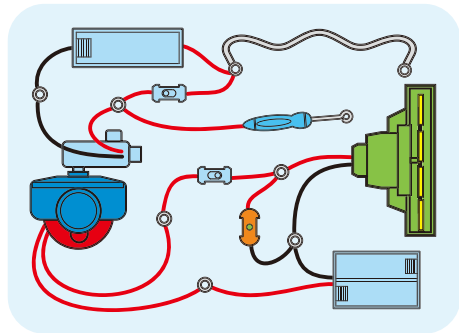

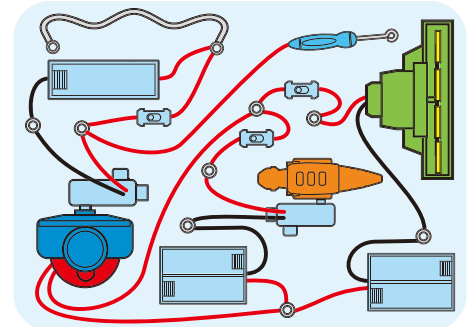
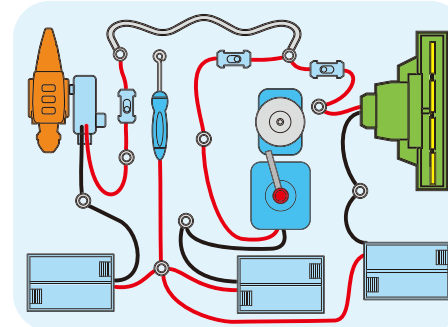
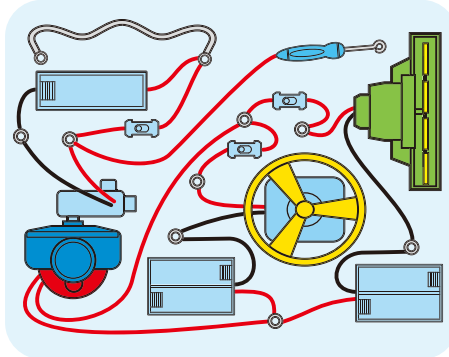
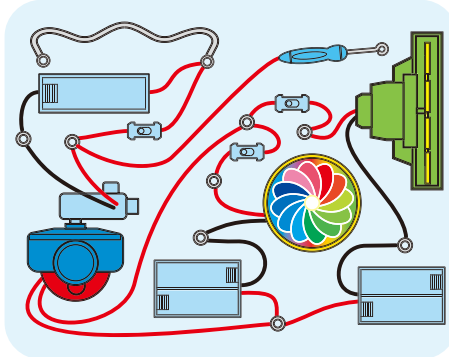
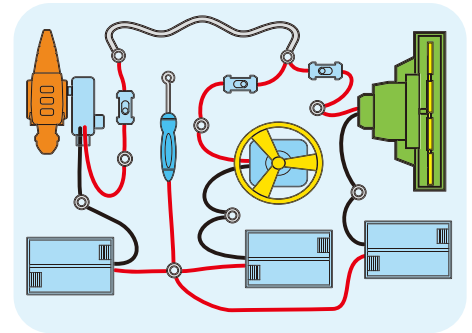
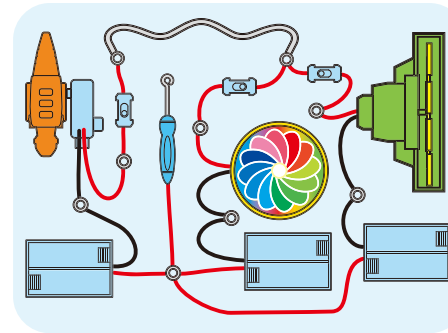
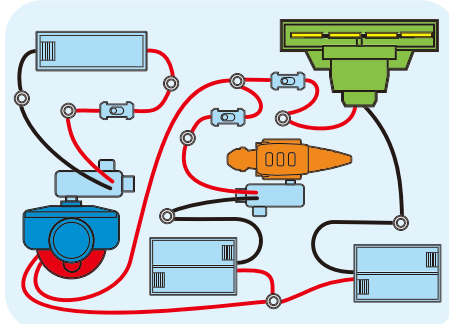
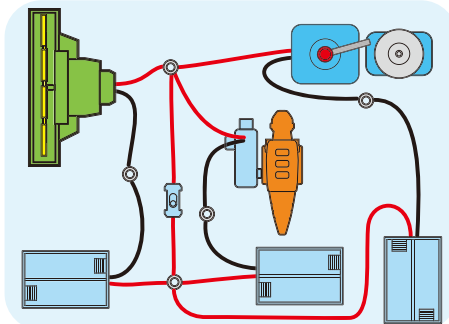
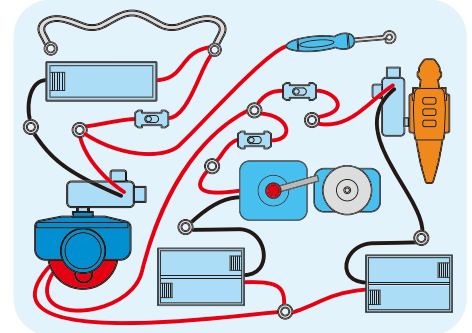
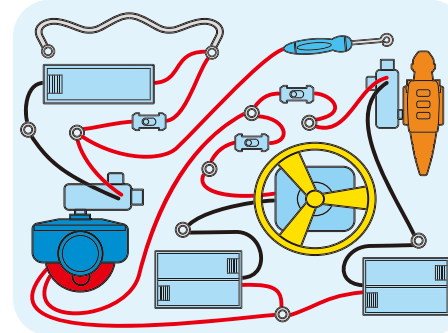
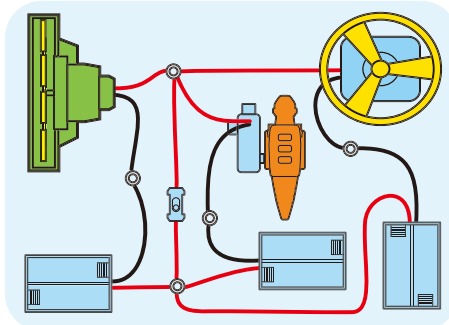
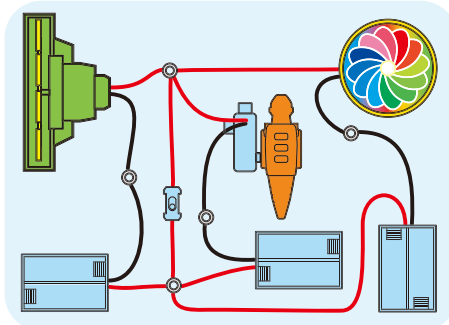
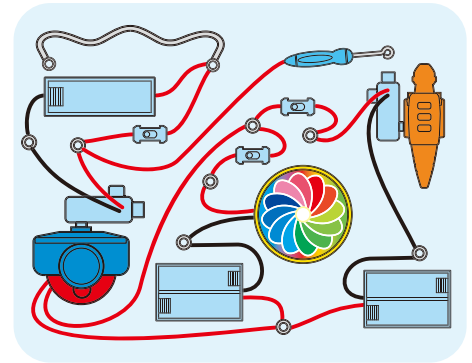
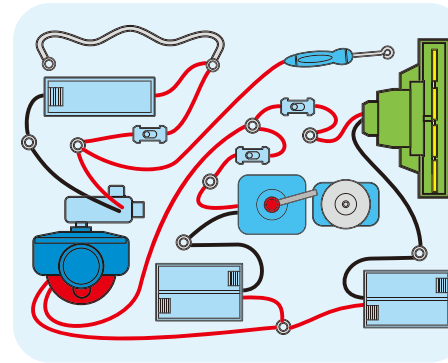
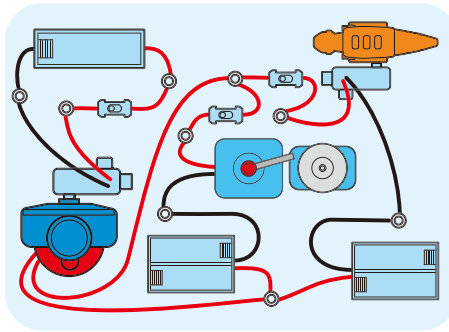
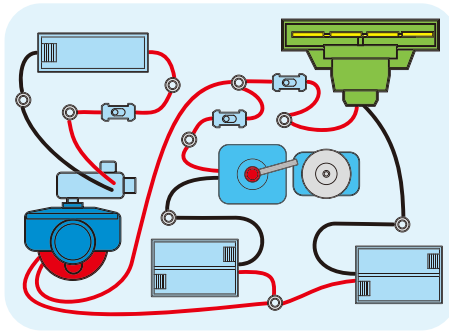

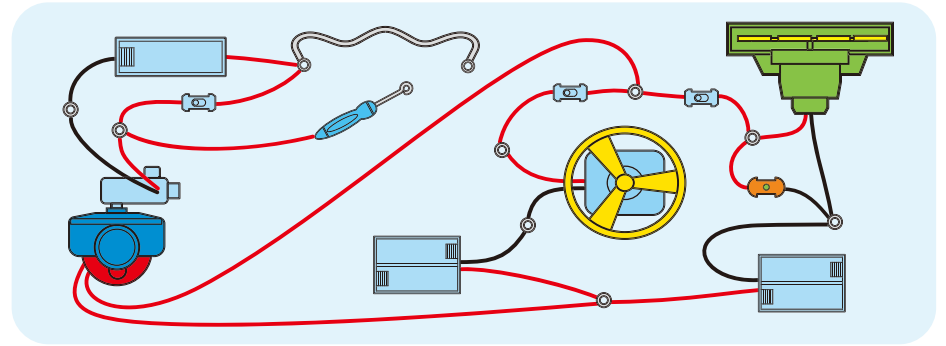
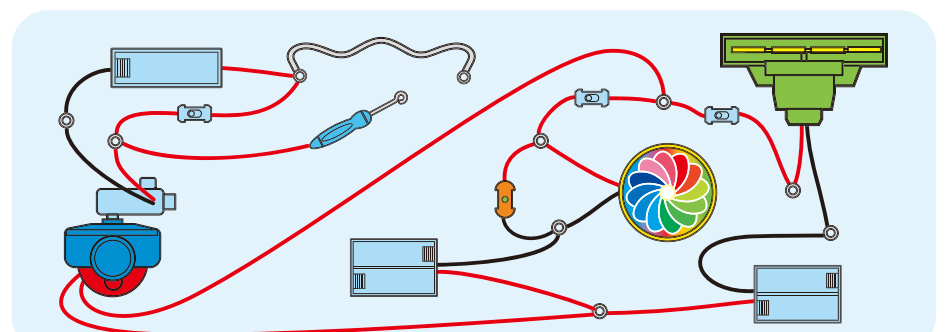
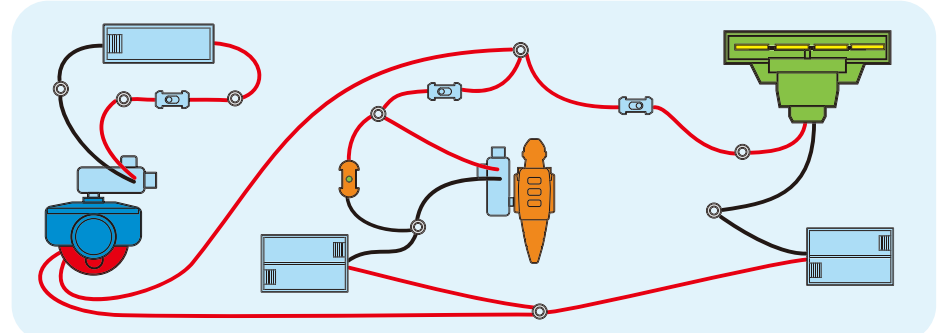
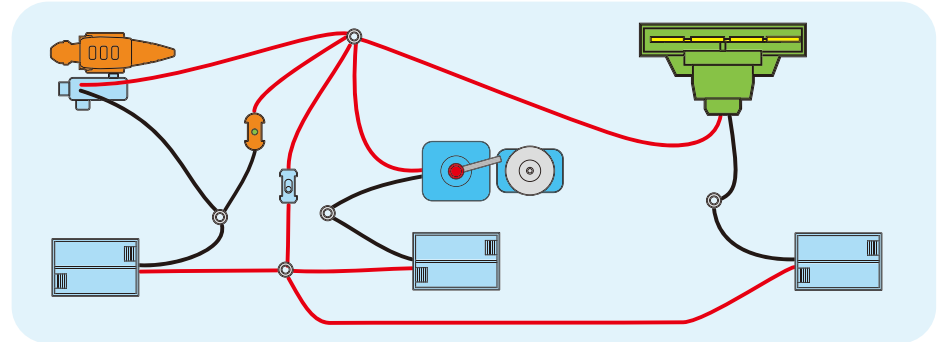
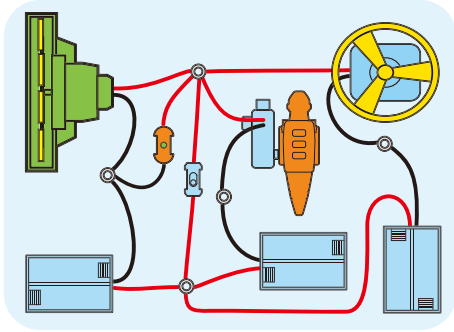
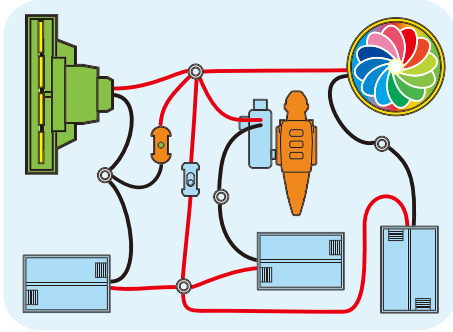
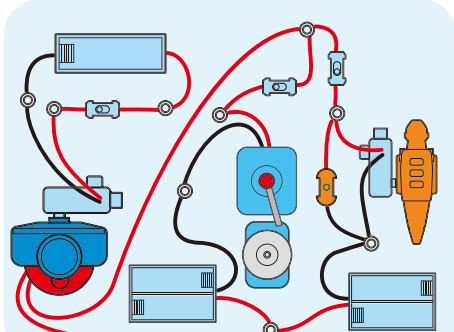
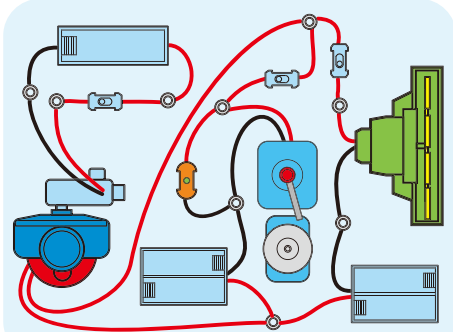
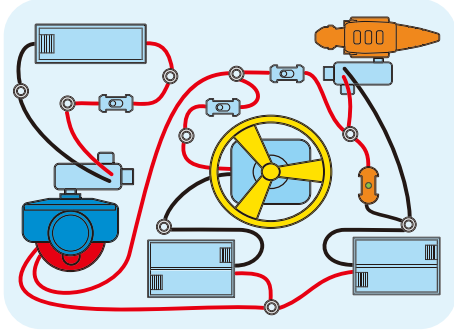
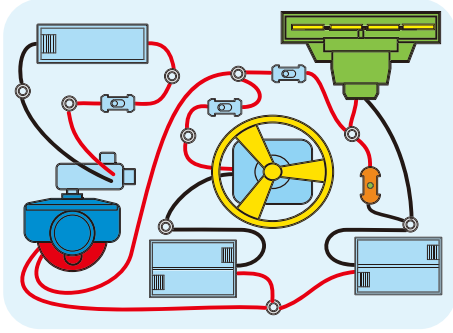
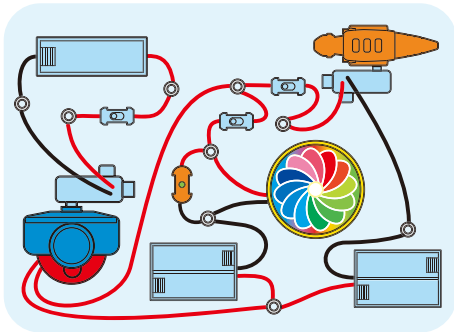
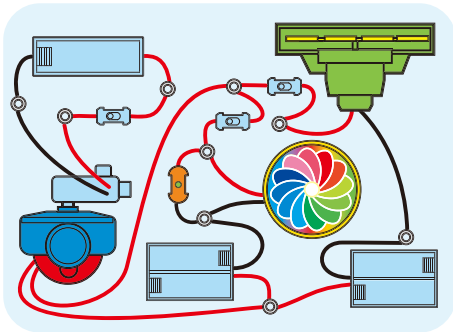

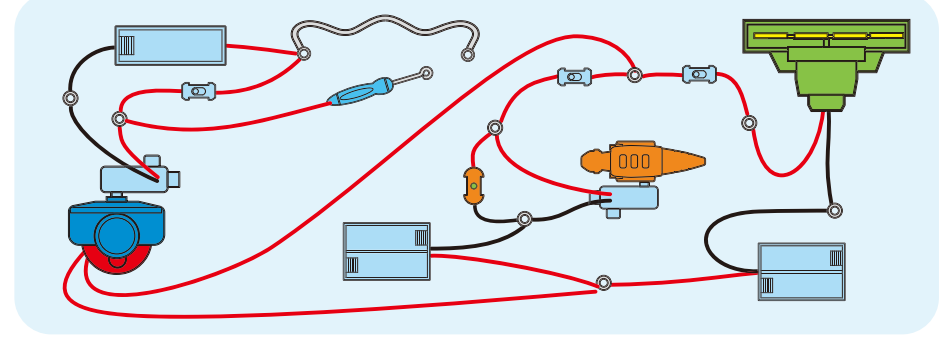
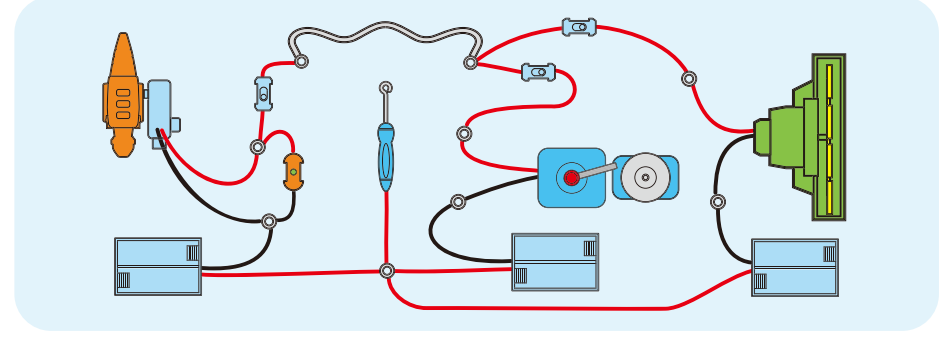
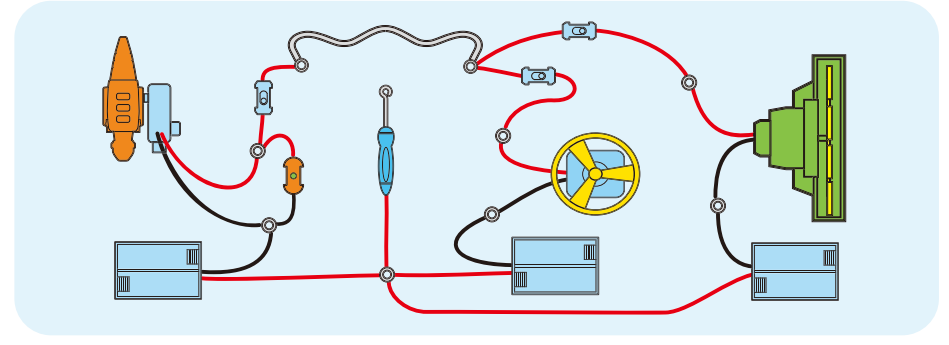
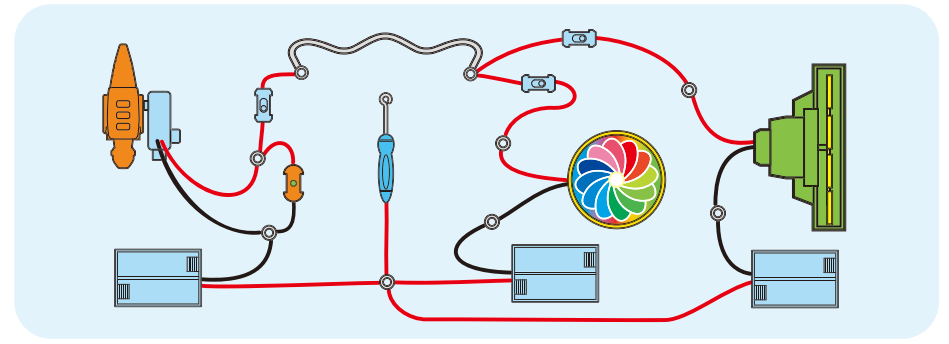
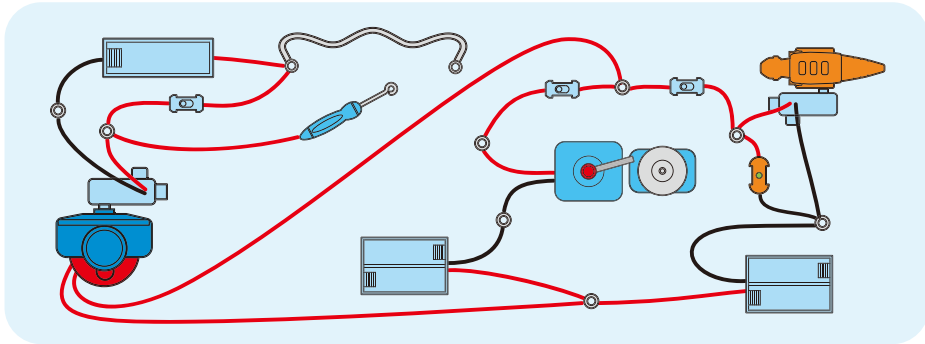
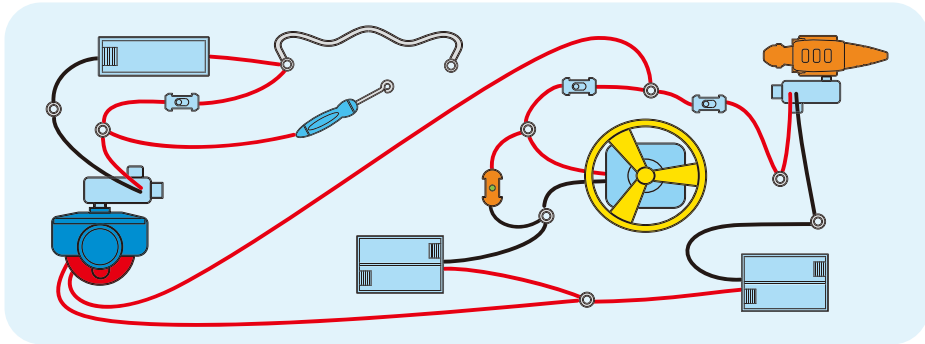
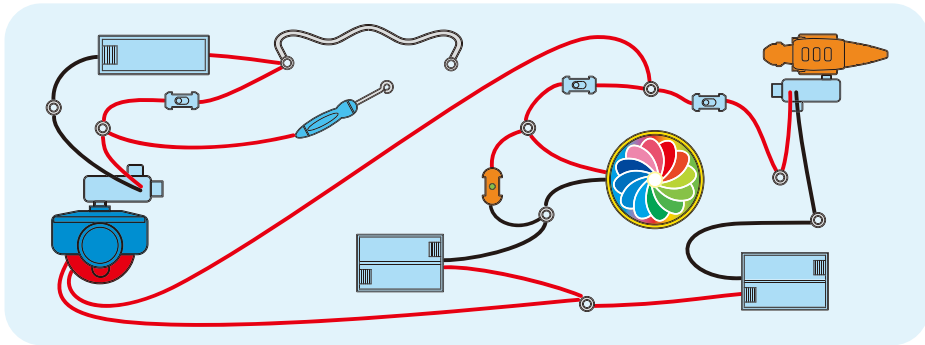
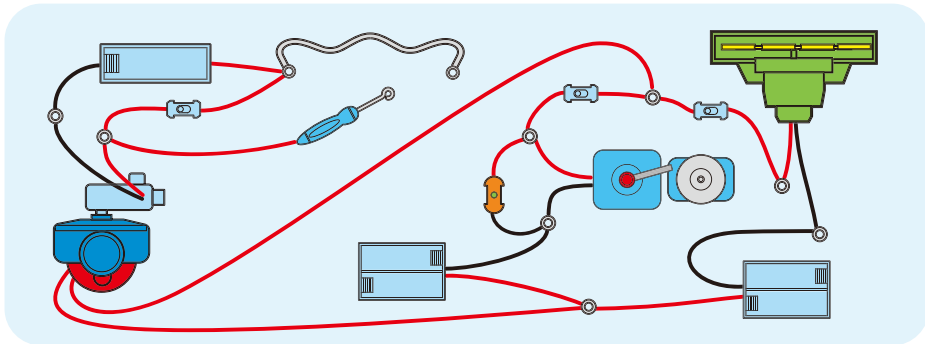



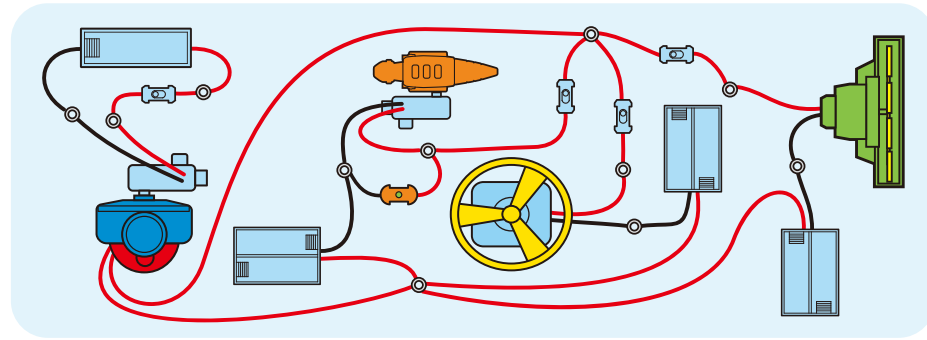
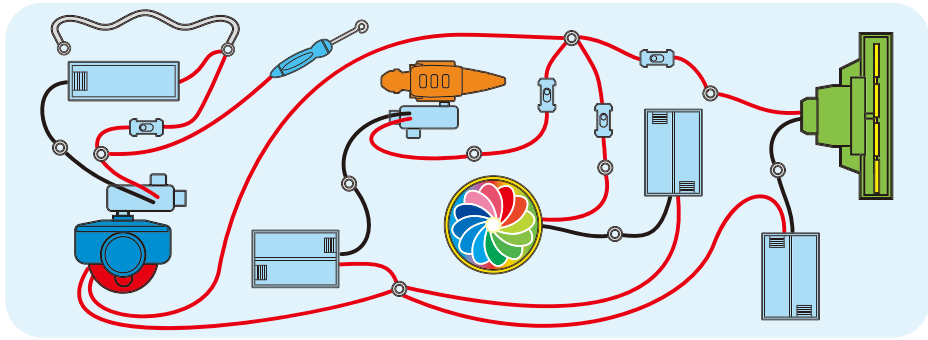
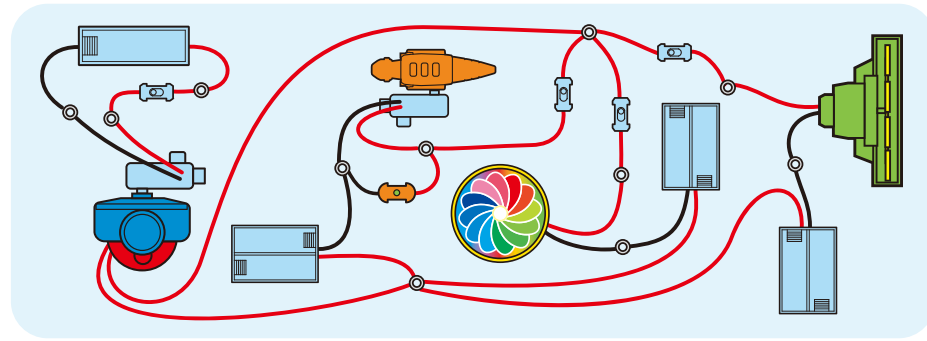
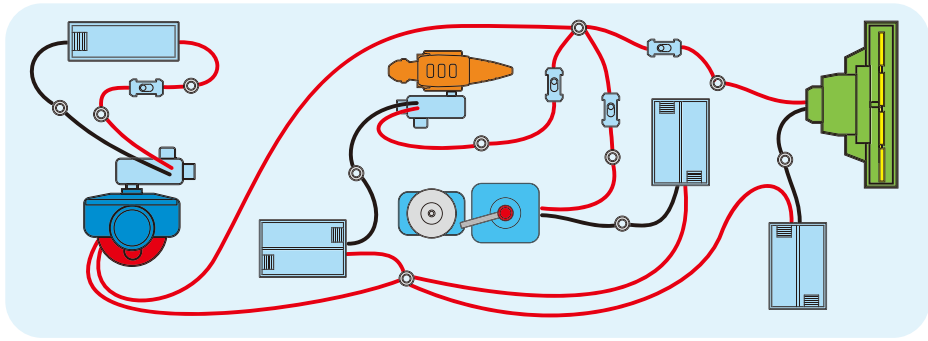
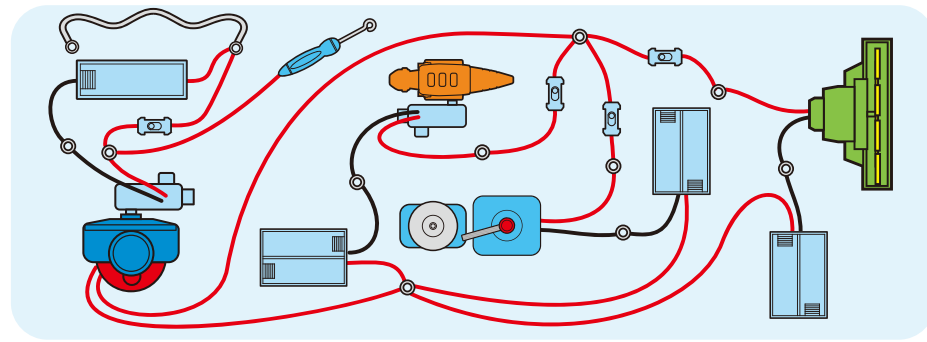
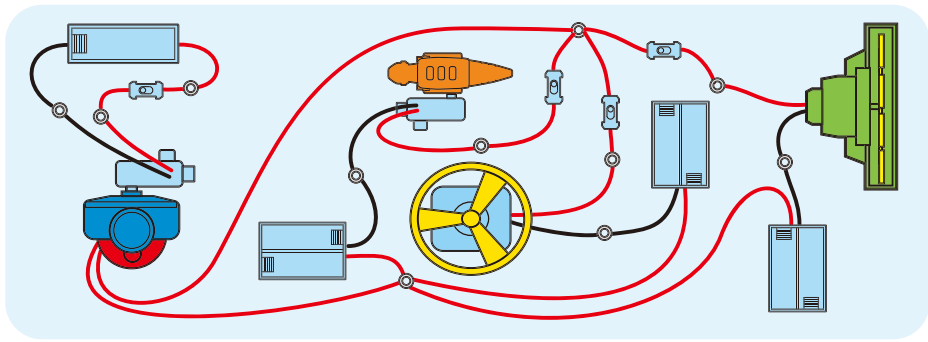
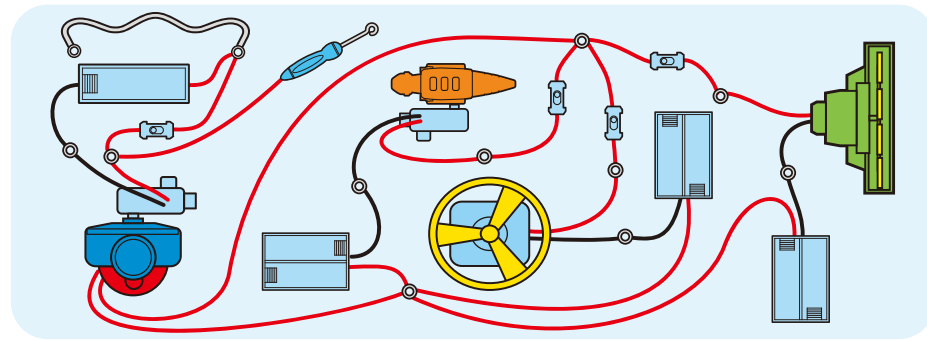
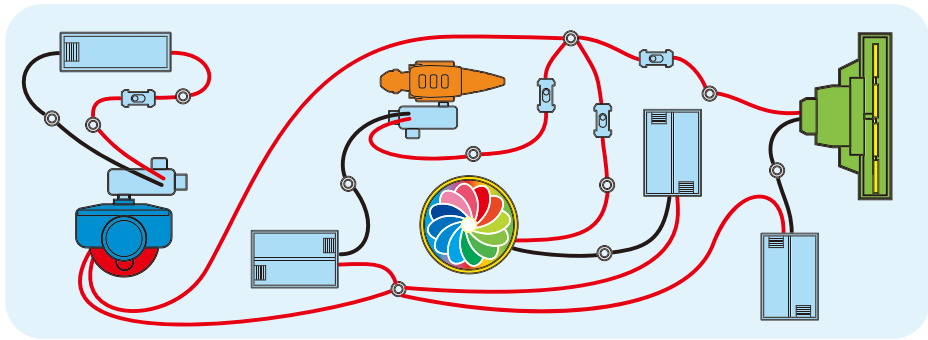

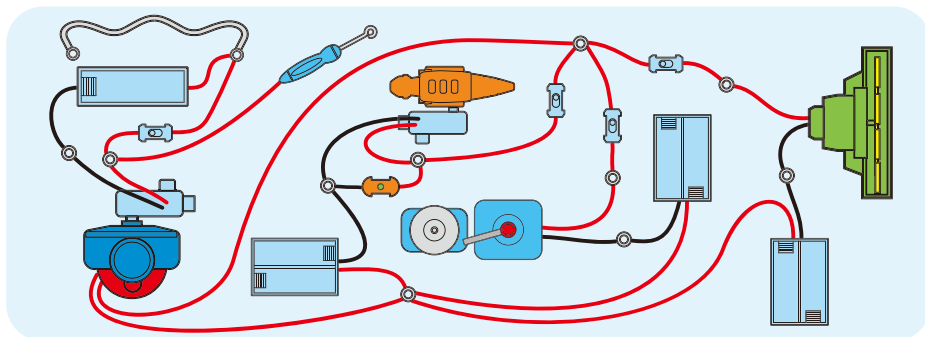
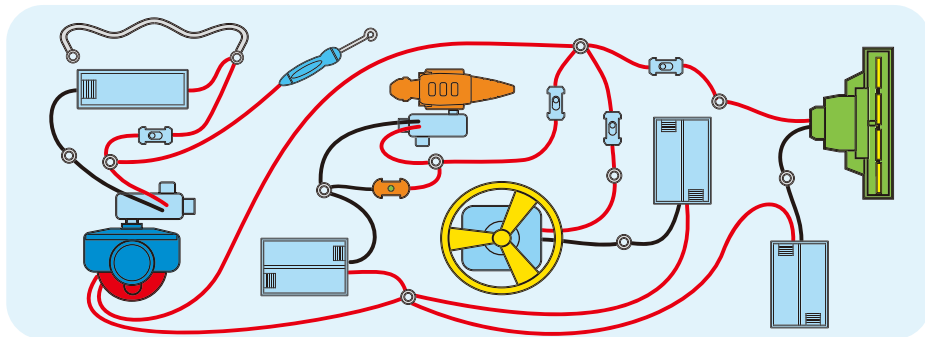
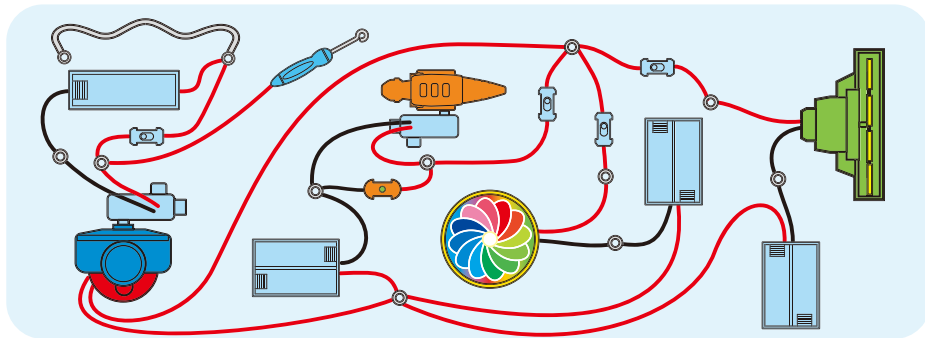
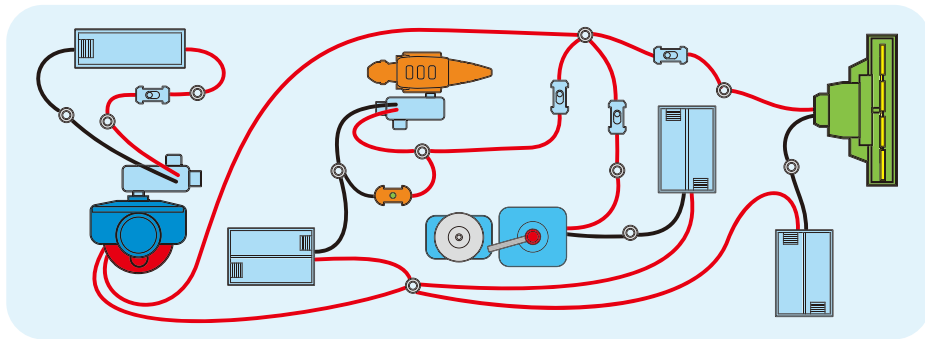

## Educational hints

### Series and Parallel Connection

Note: For the purpose of demonstration, the diagrams below are general electrical circuits in our daily life only. They are not circuits for Connex kits.

The circuit shows in fig.1 is a series circuit. It involves series connection. As electricity flows in a single path, the current flow through each device will be the same. However, if any one of the devices are broken the circuit will disconnect and will not function.

The circuit shows in fig.2 is a parallel circuit. It involves parallel connection. Each electrical device is connected in parallel. If one device is broken, the other devices can still work.

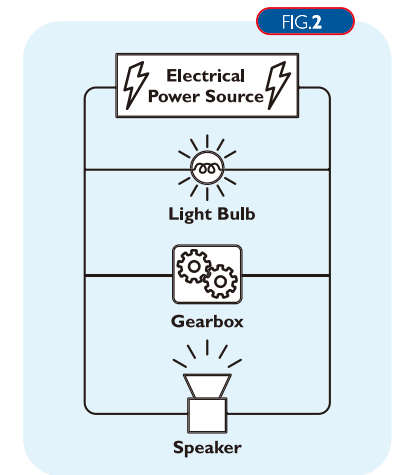
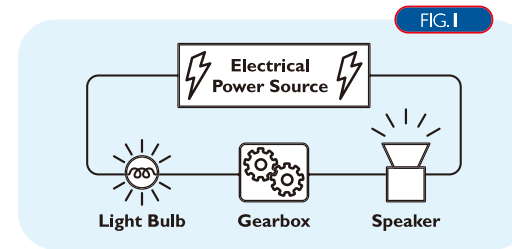

When you have worked through this set, you can even design your own circuits and create new and interesting play! The following is an example of creating an alternate 2in1 circuit for an alternate play effect:

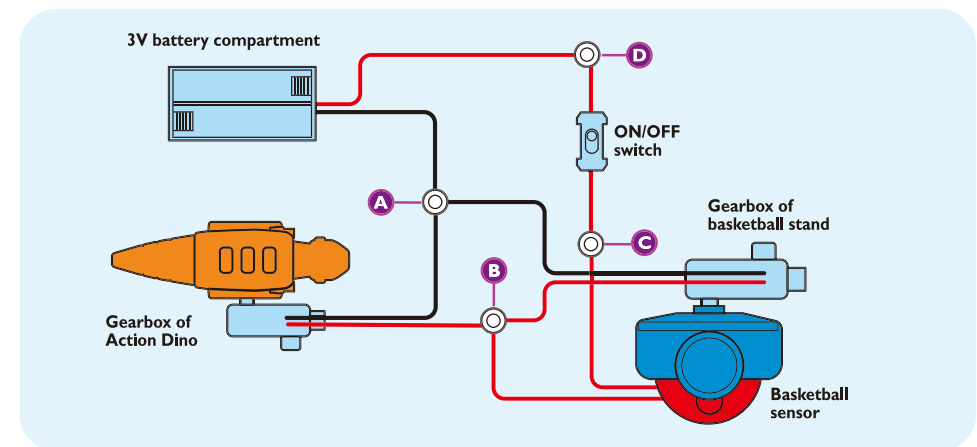

Wiring connections	Spring (A)	Spring (B)	Spring (C)	Spring (D)
3V battery compartment	black			red
ON/OFF switch			red	red
Basketball sensor		red	red	
Gearbox of basketball stand	black	red		
Gearbox of Action Dino	black	red		

Insert 2 x AA batteries and switch on the ON/OFF switch, then aim at the basket and shoot! If you make a successful shot, the Action Dino and the basketball stand will be triggered to move! As if the whole world is celebrating your successful shot.

Below is an example of creating an alternate 3in1 circuit for an alternate play effect:

Note: Only batteries of the same or equivalent types are to be used. Different types of batteries are not to be mixed, and do not mix old and new batteries. Otherwise batteries may get overheated.

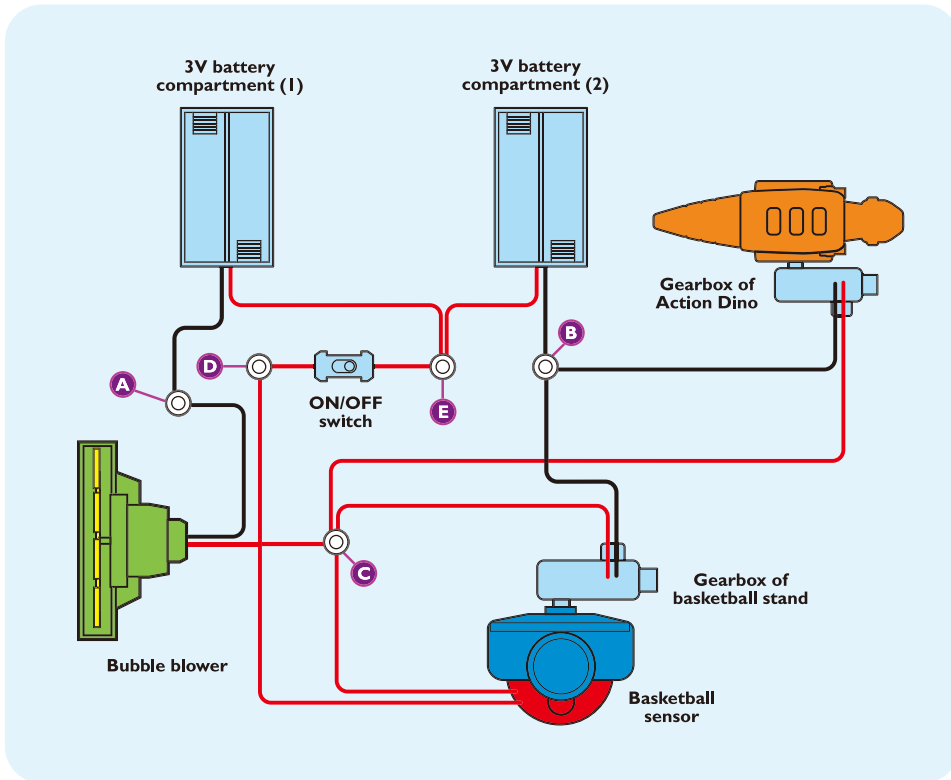

Wiring connections	Spring (A)	Spring (B)	Spring (C)	Spring (D)	Spring (E)
3V battery compartment (1)	black				red
3V battery compartment (2)		black		red	red
ON/OFF switch				red	red
Basketball sensor		black	red		
Gearbox of basketball stand		black	red		
Gearbox of Action Dino			red		
Bubble blower	black		red		

Insert 4 x AA batteries and switch on the ON/OFF switch, then aim at the basket and shoot! If you make a successful shot, then the Action Dino, bubble blower and the basketball stand will be triggered to move! See? The whole world is lighting up celebrating your triumphant shot!

The following is an example of creating an alternate 4in1 circuit for an alternate play effect:

Note: Only batteries of the same or equivalent types are to be used. Different types of batteries are not to be mixed, and do not mix old and new batteries. Otherwise batteries may get overheated.

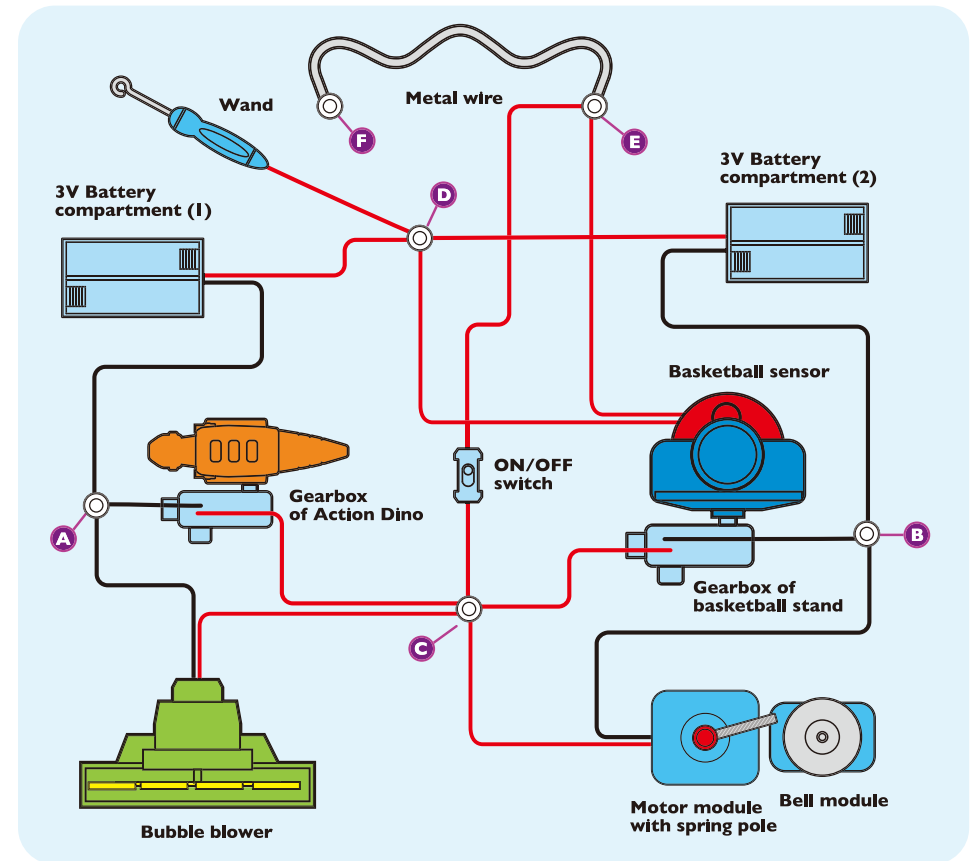

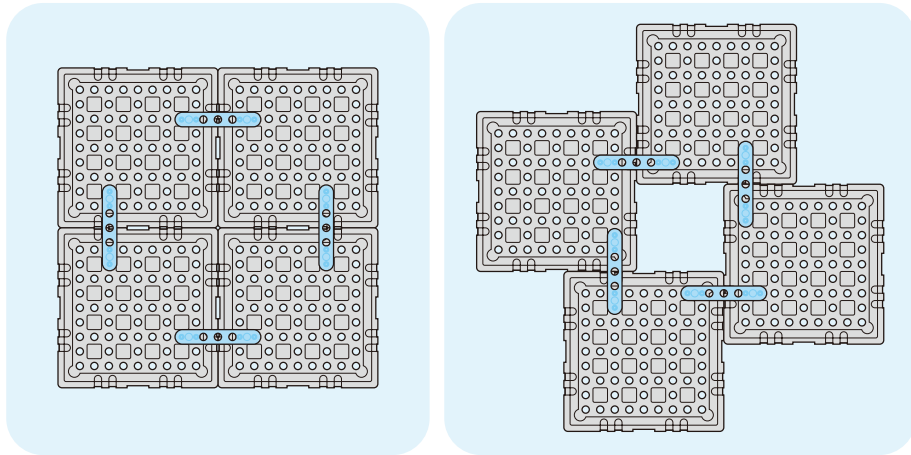

### How to Connect

Put the 2, 3 or 4 box bases together. Use connecting bridges to connect them firmly. Then follow the below connection diagrams to connect!

### Connection symbols

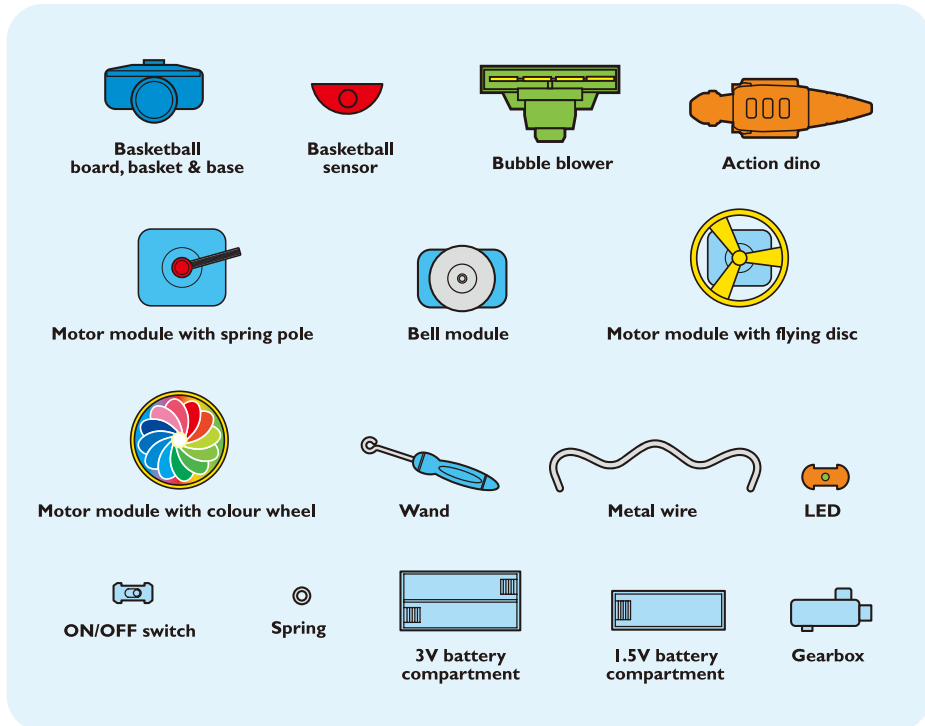

### Connection diagrams

