

Warnings!

Adult supervision is required at all times.

Please explain to your child the correct way to use this ride on toy.

The toy should be used with caution since skill is required to avoid falls or collisions causing injury to the user or third parties.

Suitable for use on flat indoor surfaces only, which are clear from obstacles or potential hazards.

Maximum weight limit 50kg.

The unassembled product contains small parts and sharp edges that are not suitable for children to access. Care should be taken in unpacking and assembly.

Fittings may loosen with use over time. Regularly check and tighten loose fittings to prevent children from removing them and to preserve the strength of the product. Do not over-tighten them.

Remove all packaging / tags before giving to a child.

Please retain this information leaflet for future reference.



John Lewis Plc
171 Victoria Street
London SW1E 5NN
johnlewis.com



Wooden ride on dog

Thank you for purchasing this toy.
Please read the instructions and warnings
carefully before use.

Assembly instructions

Adult assembly of this product is required.

6 x 48mm
Screw A

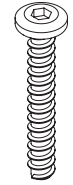

x 7

5 x 20mm
Screw B

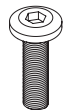

x 2

4mm

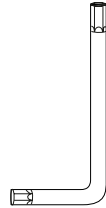

x 1

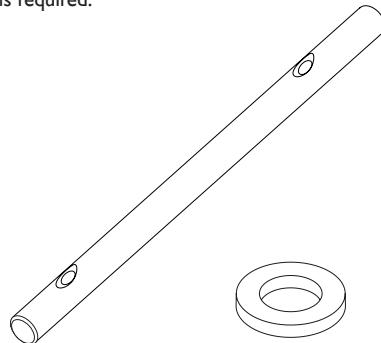

x 1

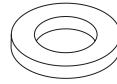

x 2

Parts list

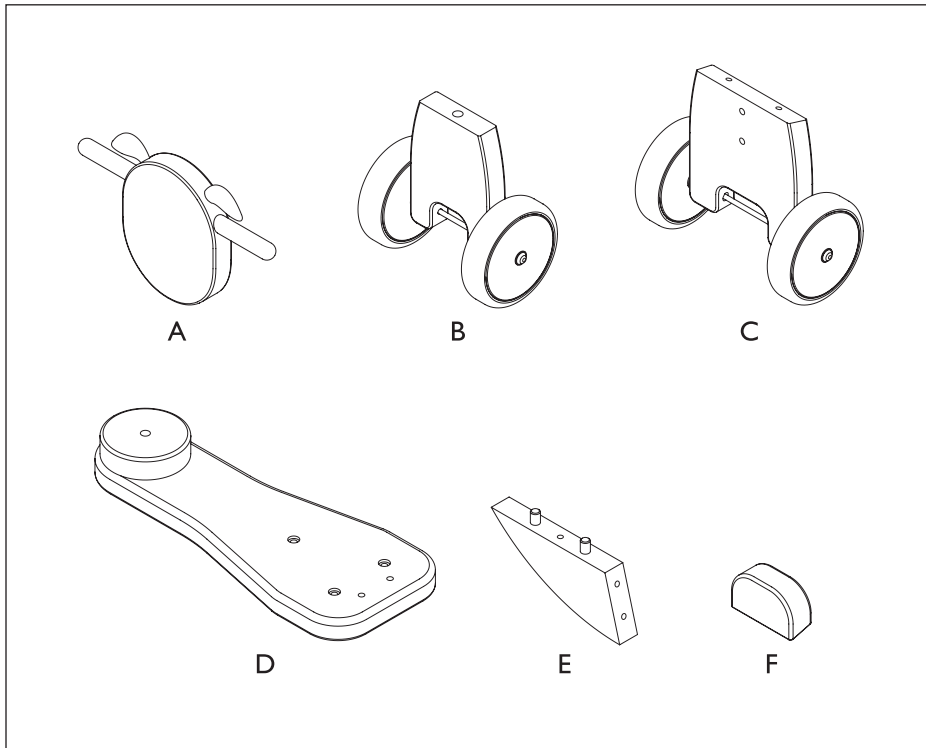

Assembly

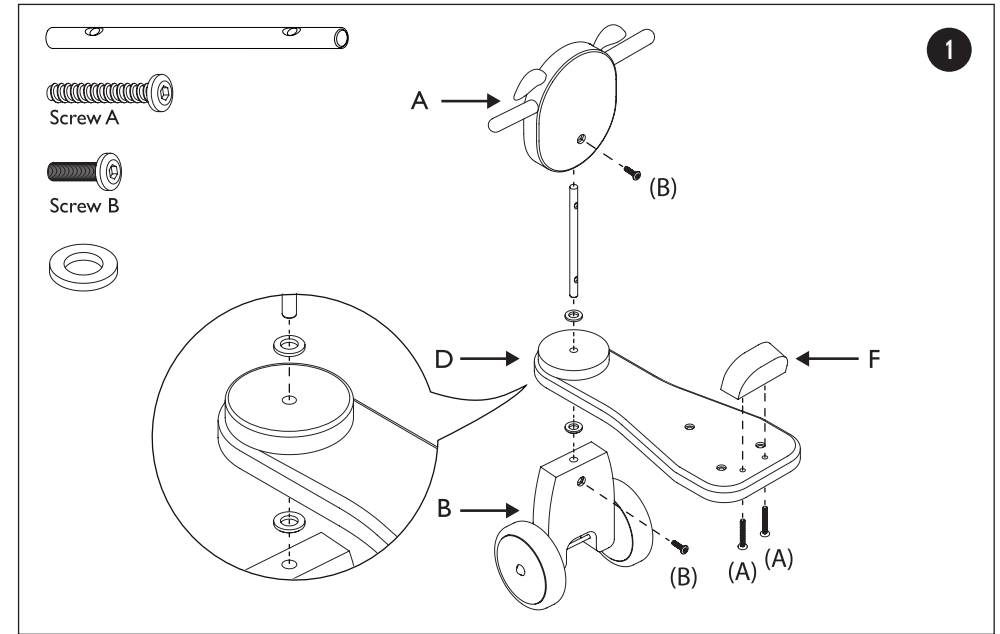

1

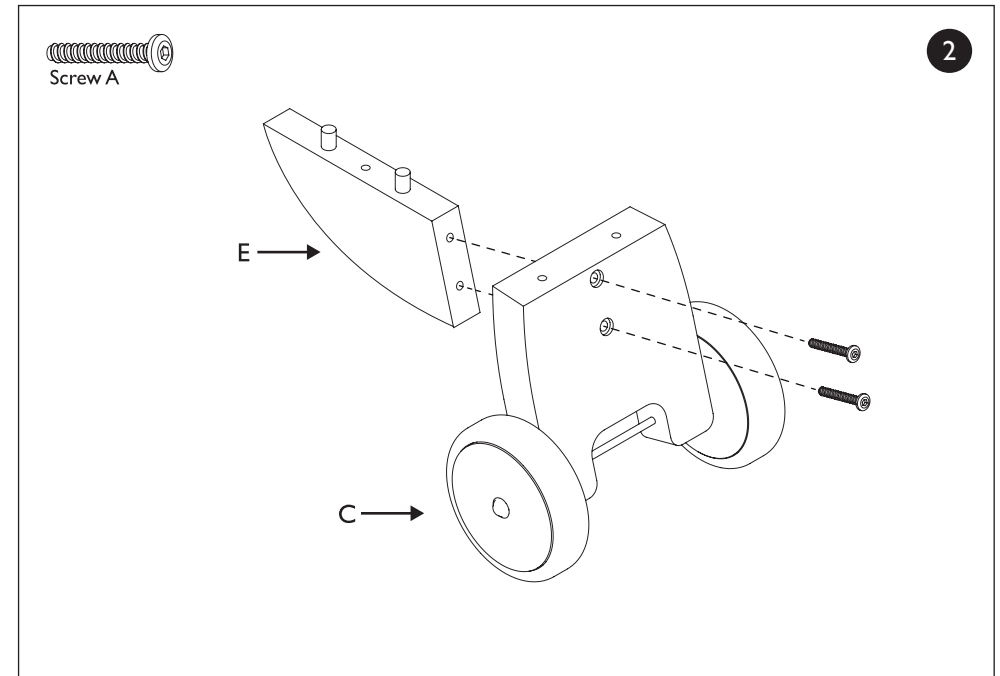

2