

## **1. About your Omni E28**

1.1 What's in the Box

1.2 Overview

1.3 Button Controls

1.4 LED Indication

## **2. Preparing Your Omni E28**

2.1 Install the Omni Station

2.2 Charge Your RoboVac

2.3 Download the App

2.4 Reset the Wi-Fi Connection

## **3. Using Your Omni E28**

3.1 Important Tips Before Use

3.2 Mapping

3.3 Set Up No-Go Zone and No-Mop Zone

3.4 Schedule Cleaning

3.5 Select a Cleaning Mode

## **4. Using the Mopping System**

## **5. Using RoboVac with Alexa, Siri, or Google Assistant Compatible Devices**

## **6. Enabling / Disabling Child Safety Lock**

## **7. Using the Portbale Deep Cleaner**

7.1 Preparing Your Portable Deep Cleaner

7.2 Start Cleaning

7.3 Enabling Self-cleaning Mode

7.4 After Use

## **8. Cleaning and Maintenance**

8.1 Clean the Dustbin and Filter

8.2 Clean the Rolling Brush

8.3 Clean the Side Brush and CornerRover Arm

8.4 Clean the Sensors, Cameras, and Charging Pins

8.5 Clean the Dirty Water Tank

8.6 Clean the Cleaning Tray

## **9. Troubleshooting**

## **10. Specifications**

## **11. Customer Service**

# 1. About your Omni E28

## 1.1 What's in the Box



Portable Deep Cleaner



Omni Station



Robot Vacuum Cleaner (RoboVac)

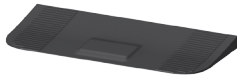

Detachable Base

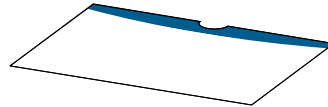

Quick Start Guide



Safety Sheet

## 1.2 Overview



- 1 RGB Camera+ LED Light
- 2 Buttons
- 3 Navigation Lidar
- 4 Dirty Water Collection Port
- 5 Charging Contact Pins (\*2)
- 6 Water Injection Port

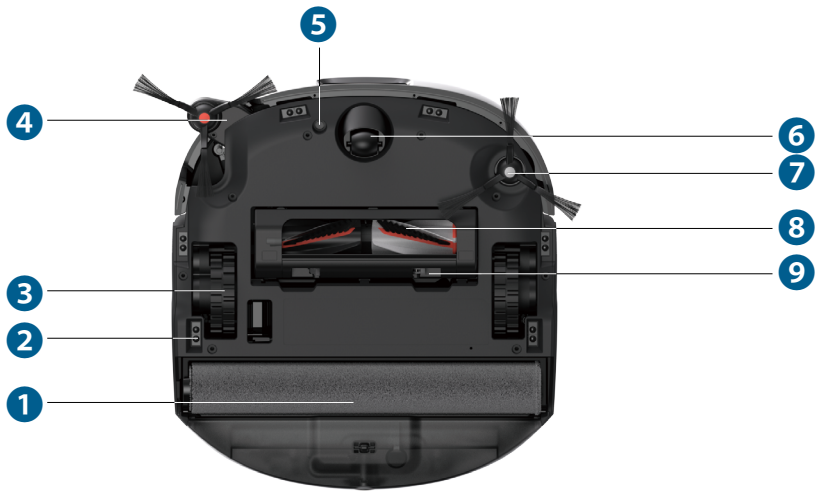

- 1 Detachable Mopping Roller
- 2 Drop Sensors (×6)
- 3 Wheels (×2)
- 4 CornerRover Arm
- 5 Carpet Detection Sensor
- 6 Swivel Wheel
- 7 Side Brush
- 8 DuoSpiral™ Brushes
- 9 Brush Guard

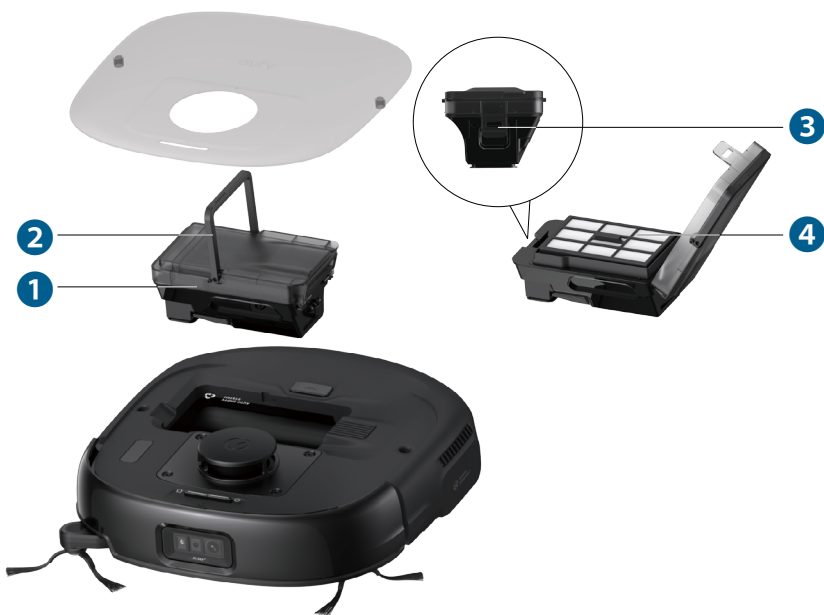

- 1 Dustbin
- 2 Handle
- 3 Release Latch
- 4 Filter



- 1 Detachable Base
- 2 Cleaning Tray
- 3 LED Indicator
- 4 Clean Water Tank
- 5 Dirty Water Tank
- 6 Air Outlet  
(with Removable Noise-Reduction Foam Inside)
- 7 Disposable Dust Bag











- 1 Self-cleaning Button**
  - Press to enable self-cleaning of the Portable Deep Cleaner
- 2 Spray Trigger**
  - Press and hold to dispense water
- 3 Nozzle**
- 4 Power Button**
  - Press to power on or off the Portable Deep Cleaner
- 5 Cleaning Brush**

### 1.3 Button Controls

	<ul style="list-style-type: none"> <li>• Long press (3s): Power on or off</li> <li>• Short press: Pause / resume the current task when working</li> </ul>
	<ul style="list-style-type: none"> <li>• Short press: Return RoboVac to the Omni Station</li> </ul>
	<ul style="list-style-type: none"> <li>• Long press simultaneously (3s): Reset the Wi-Fi connection</li> </ul>

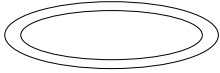
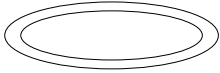
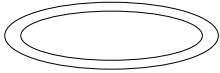
## 1.4 LED Indication

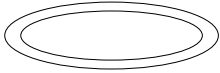
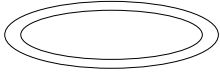
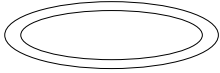
You can see the status of RoboVac, OmniStation and Portable Deep Cleaner from the LED indicators.

	LED Indication	Description	Status
RoboVac		Pulsing white	Powered On
		Steady white	Working normally
		Breathing red	Low battery
		Steady red	<ul style="list-style-type: none"> <li>• Low battery</li> <li>• Error (Please refer to in-app instructions for solutions)</li> </ul>
		Flashing red quickly	Error (Please refer to in-app instructions for solutions)
Omni Station		The ring lights up in white	Powered on
		Steady white	Working normally
		Breathing white	Dust collection / Mop cleaning
		Steady red	Error (Please refer to in-app instructions for solutions)
		Off	Power disconnected
Portable Deep Cleaner		Steady white	<ul style="list-style-type: none"> <li>• Connected to power</li> <li>• Working normally</li> </ul>
		Flashing white (three times)	The Portable Deep Cleaner is placed back on the Omni Station
		Breathing white	Pressing on the spray trigger / self-cleaning button
		Steady red	Error (Please refer to in-app instructions for solutions)
		Off	Power disconnected

## 2. Preparing Your Omni E28

### 2.1 Install the Omni Station

1. Add the Floor Cleaner to the Omni Station.

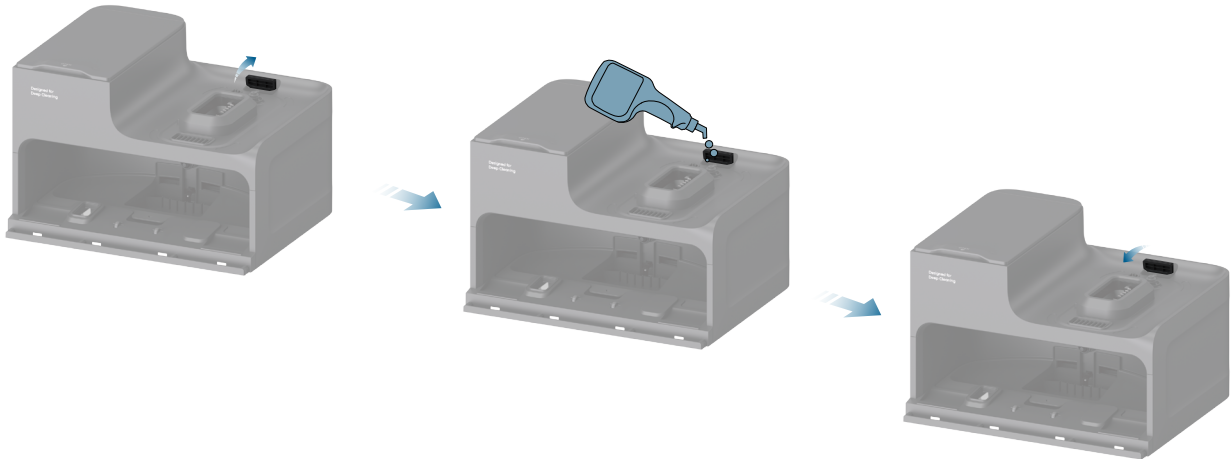

2. Assemble the Portable Deep Cleaner onto the Omni Station.



3. Install the detachable base by pressing down both sides of it firmly.



- Make sure the detachable base is seamlessly connected to the Omni Station, otherwise the robot will fail to return to the Omni Station smoothly.

4. Place the Omni Station in a location that has strong Wi-Fi signal and the robot can easily access. It is recommended to place it against a wall and on a hard, level surface. Connect the power cord to the Omni Station and a wall outlet. When the Omni Station connects to AC power, the LED ring of the clean water tank will light up in white.

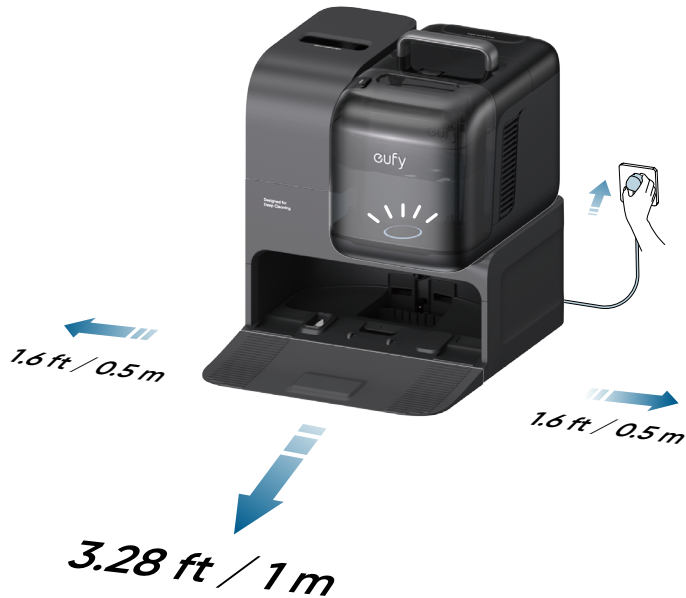

- The recommended clearance on the illustration is a suggested value based on testing, to ensure the robot operates optimally, returns to the station for charging, and cleans the designated area effectively. You may adjust the clearance distance as necessary to suit the actual working environment of the robot.
- Always keep the Omni Station plugged in to ensure the infrared connection between the robot and the Omni Station is successful, otherwise the robot will not automatically return to it.

5. Take out the clean water tank. Add clean water until it reaches the MAX water line.

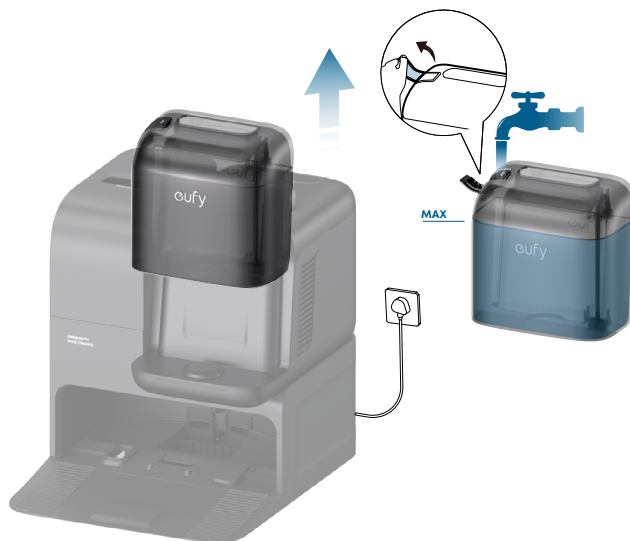

- Please do not add hot water into the tank to avoid shortening its service life.

6. Reinstall the clean water tank. Ensure that both the clean water tank and dirty water tank are securely locked; otherwise the station will not operate normally during subsequent use.



## 2.2 Charge Your RoboVac

1. Remove the foam blocks and all the protective films on RoboVac.



2. Attach the robot to the Omni Station. RoboVac will power on and start charging automatically.



## 2.3 Download the App

To enjoy all the available features, it is recommended to download the app.

1. Download the app from the App Store (iOS devices) or Google Play (Android devices). You can also get the app by scanning the QR code printed on the Quick Start Guide (included in the package).

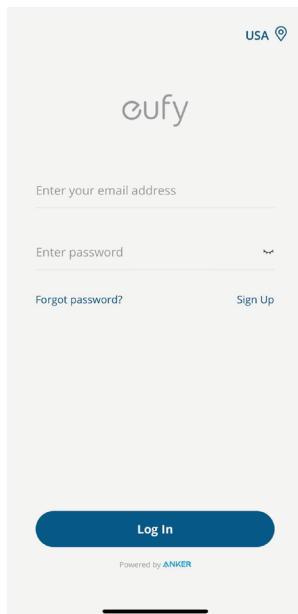

2. Open the app, create a new account or log into your own eufy account.

3. Tap the "+" icon to add the device.

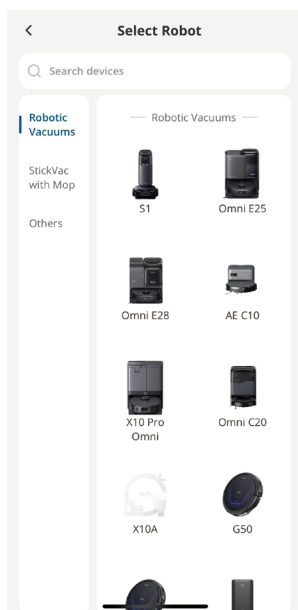

4. Follow the instructions in the app to set up the Wi-Fi connection.

## 2.4 Reset the Wi-Fi Connection

If you bump into issues when connecting your RoboVac to the eufy app, try to reset the Wi-Fi connection. Press and hold the power and recharge buttons simultaneously for 3 seconds until you hear a voice prompt.



You will hear a voice prompt when the Wi-Fi connection has been reset, and the LED indicators on RoboVac will quickly flash white. Now you can follow the instructions in the app to set up the Wi-Fi connection.

## 3. Using Your Omni E28

 • All UI images shown in this section are for illustration only, and they may be subject to change due to software updates. Please refer to the actual App interface for the most accurate information.

### 3.1 Important Tips Before Use

#### 3.1.1 For RoboVac

- A. Remove power cords and small objects (socks/toys/slippers/towels/weighing scales, etc.) from the floor that may entangle RoboVac.
- B. Fold tasseled edges of rugs underneath to prevent tangling RoboVac. Avoid cleaning high-pile rugs or rugs thicker than 0.83 in / 21 mm as they may cause RoboVac to malfunction.
- C. Before mapping, it is strongly recommended to place physical barriers in front of fireplaces and certain areas (i.e. air vents) that may cause damage to the robot if entered. For future use, set up virtual boundaries in the eufy app to prevent the robot from falling down staircases.
- D. Avoid vacuuming large amounts of water as it will potentially damage the device.
- E. RoboVac may climb on top of objects less than 0.83 in / 21 mm in height. Remove these objects if possible.
- F. Anti-drop sensors will prevent RoboVac from tumbling down stairs and steep drops in most cases. Sensors are less effective if dirty or used on carpeted / reflective floors. Place physical barriers or set a "No-Go" zone to block off areas where RoboVac may fall.

#### 3.1.2 For Portable Deep Cleaner

- A. Before using the Portable Deep Cleaner (PDC) for fabric cleaning, ensure the water tank is filled with clean water. Do not use corrosive or flammable liquids.
- B. Do not use the PDC on delicate fabrics or surfaces that may be damaged by water or vigorous scrubbing. Test on a small, inconspicuous area before cleaning the entire surface.
- C. Ensure the PDC's power cord is fully extended and not tangled during use to avoid tripping hazards or damage to the cord.
- D. After use, empty the dirty water tank and clean the spray nozzle and brush to prevent clogging or residue buildup.
- E. When returning the PDC to the base station, ensure the hose is properly coiled to avoid damage or tangling.

## 3.2 Mapping

This feature is designed to help your robot efficiently learn the layout of your home, ensuring thorough and systematic cleaning. By creating a detailed floor plan, your robot can navigate and clean with precision.

To maximize the efficiency and accuracy of the mapping process, please follow these steps:

- **Open All Doors:** Ensure all doors within the cleaning area are open. This allows the robot to access and map each room seamlessly.
- **Block Off Restricted Areas:** If there are specific zones you don't want the robot to enter, use physical barriers to block these areas. This can enhance mapping accuracy and prevent the robot from entering unwanted spaces. After the mapping is completed, you can remove physical barriers, and set up restricted areas to prevent the robot from entering those areas.
- **Remove Obstacles:** Clear any objects, such as toys, cables, or small furniture, that might obstruct the robot's path or become entangled in its brushes. This helps the robot move freely and map the area without interruptions.
- **Do Not Move the Base Station:** Once the floor plan is created, avoid relocating the base station. The robot relies on the base station as a reference point for navigation and mapping. Moving it may disrupt the accuracy of the floor plan.

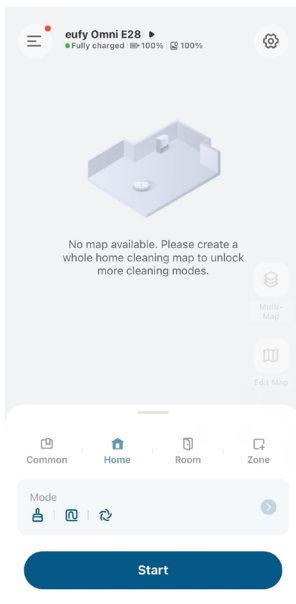

To start the mapping process, tap "**Start**" in the app.

### 3.3 Set Up No-Go Zone and No-Mop Zone

With the eufy app, you can set up a “No-Go Zone” or “No-Mop Zone” as a restricted area. This eliminates the need to use physical barriers, including boundary strips. This feature is only designed for dividing the cleaning zones, not for isolating hazardous areas.

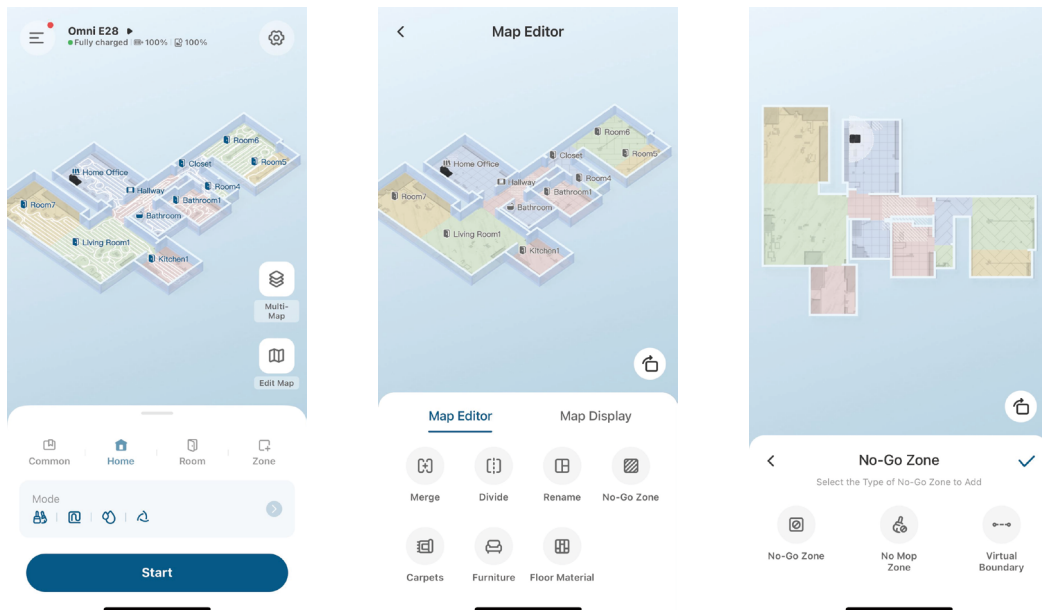

### 3.4 Schedule Cleaning

With the eufy app, you can schedule RoboVac to start cleaning at a particular time.

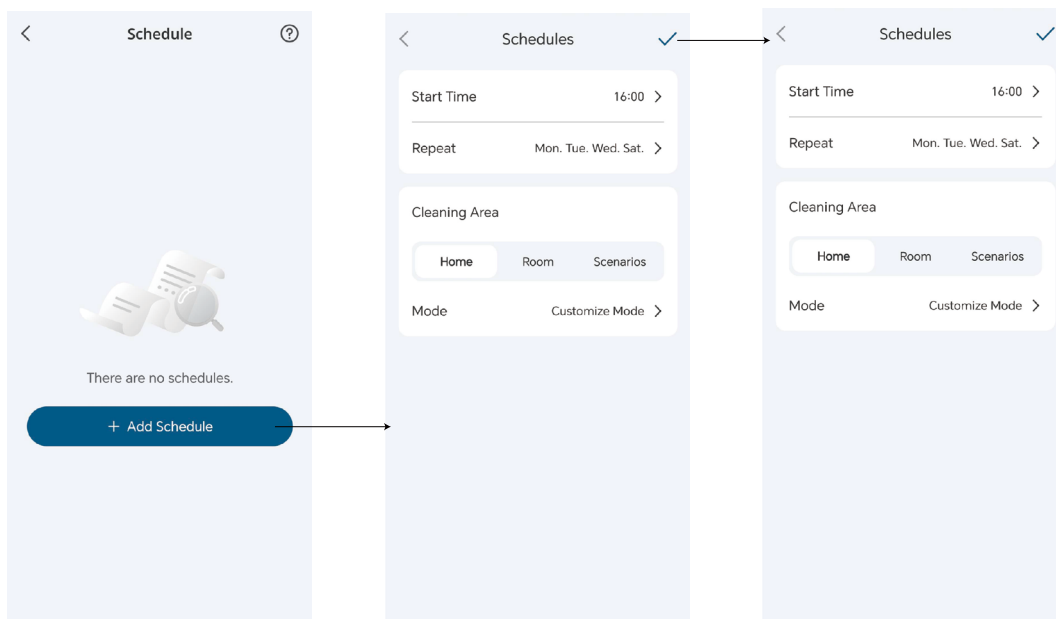

- 💡 You can set the time and customize cleaning schedules from Sunday to Saturday on the eufy app. This function is only available on the app.
- During the Do Not Disturb period, RoboVac will remain silent, with automatic dust collection and voice notifications disabled.

### 3.5 Select a Cleaning Mode

You can start / pause cleaning or select the desired cleaning mode via the eufy app.

In each cleaning mode, you can further customize the modes, duration, water level, suction level, and other settings.

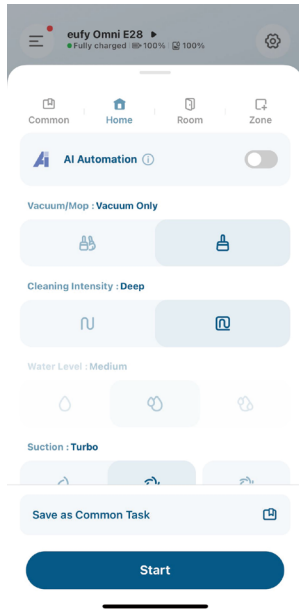

#### 3.5.1 House Cleaning Mode

Tap "Start" in the eufy app to enable House Cleaning mode.

After startup, RoboVac moves from the Omni Station and automatically determines its cleaning route. When cleaning is finished, RoboVac automatically returns to the Omni Station.

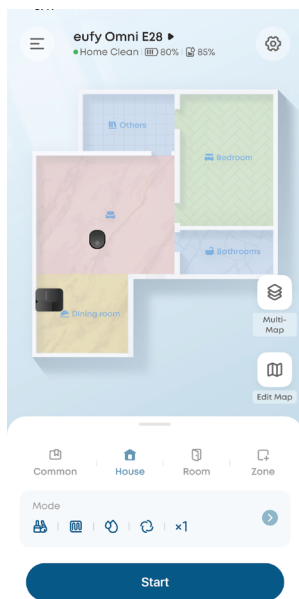

- To pause cleaning, tap "Pause" in the eufy app, or press the power button on RoboVac.

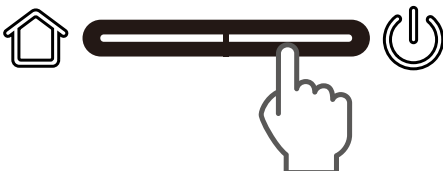

### 3.5.2 Room Cleaning Mode

In this mode, your house is automatically divided into several rooms for cleaning in the eufy app. You can also customize your room settings in the app. RoboVac will clean the selected rooms only and return to the Omni Station after cleaning.

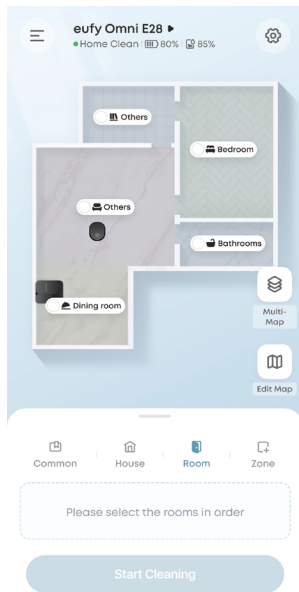

- 💡 • Enable Room Cleaning mode only after RoboVac has created the map.
- It is recommended that RoboVac moves from the Omni Station to start room cleaning.

### 3.5.3 Zone Cleaning Mode

In this mode, you can set up a cleaning zone and customize its size in the eufy app, RoboVac will clean the selected zone only.

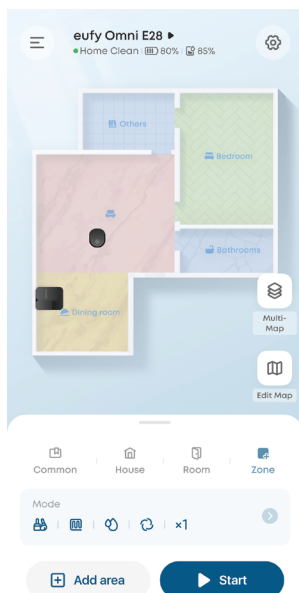

## 4. Using the Mopping System

1. Start cleaning. RoboVac will automatically vacuum and mop. During mopping, you can choose between three water levels via the eufy app.
2. Regularly empty and clean the dirty water tank to prevent mildew or unpleasant smells. For instructions on how to clean the dirty water tank, refer to the "**Cleaning and Maintenance**" section in this User Guide.

## 5. Using RoboVac with Alexa, Siri, or Google Assistant Compatible Devices

Amazon Alexa or the Google Assistant are smart voice control devices that enable you to control RoboVac with your voice.

### Before you start, make sure:

- RoboVac is attached to the Omni Station to ensure there is enough power.
- RoboVac is connected with the eufy app.
- To control your RoboVac with Siri, make sure you have an iPhone or iPad running a recent version of iOS.

### To control RoboVac with Alexa, Siri, or Google Assistant:

1. Click on the top left corner of eufy app's main interface, then find "**Smart Integrations**" in the dropdown menu.
2. Follow the on-screen instructions to complete the setup.

## 6. Enabling / Disabling Child Safety Lock

Activate the child safety lock in the eufy app: **More Setting > Child Lock**

Once the child safety lock is enabled, all buttons will be locked to prevent children from damaging the device or accidentally getting hurt.

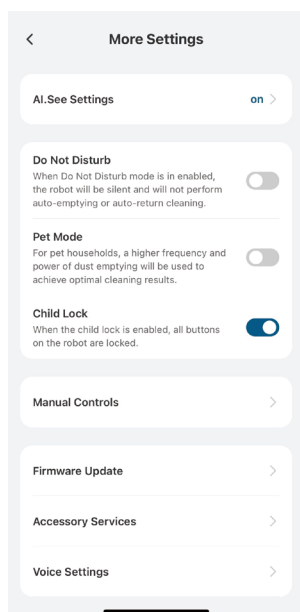

## 7. Using the Portbale Deep Cleaner

### 7.1 Preparing Your Portable Deep Cleaner

1. Unplug the Omni Station, then remove the cleaner's cover and detach the cleaner from the Omni Station.



2. Move the cleaner to the area that needs cleaning, then connect it to a power source.



## 7.2 Start Cleaning

1. Remove the nozzle from the slot, then unwind the coiled water hose from the cleaner.



2. Spray an appropriate amount of fabric cleaner onto the stain and let it sit for 1 minute.

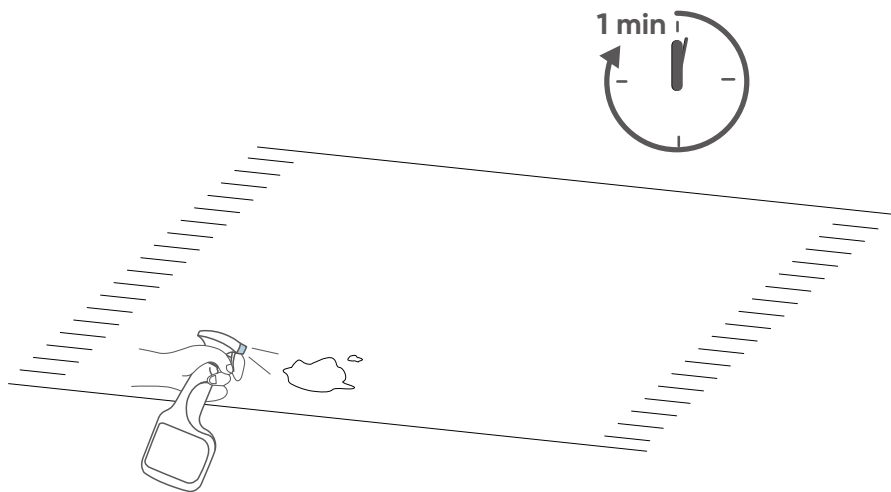

3. Press and hold the spray trigger to dispense water evenly over the stained area, such as carpets, sofas, or other fabric surfaces. This will help dissolve the stain. Then, use the brush to gently scrub the surface while the cleaner simultaneously extracts the water and stain mixture.

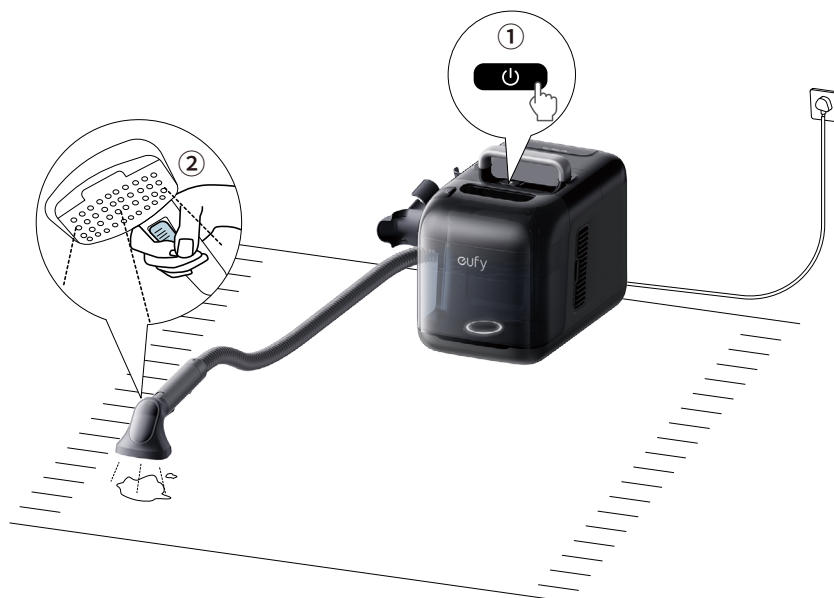

- 💡 • After cleaning, allow the cleaner to run for an additional 5 seconds before turning it off. This will enable the fan to extract any remaining water from the hose.

### 7.3 Enabling Self-cleaning Mode

After cleaning, press the self-cleaning button to automatically clean the inside of the hose and the nozzle.

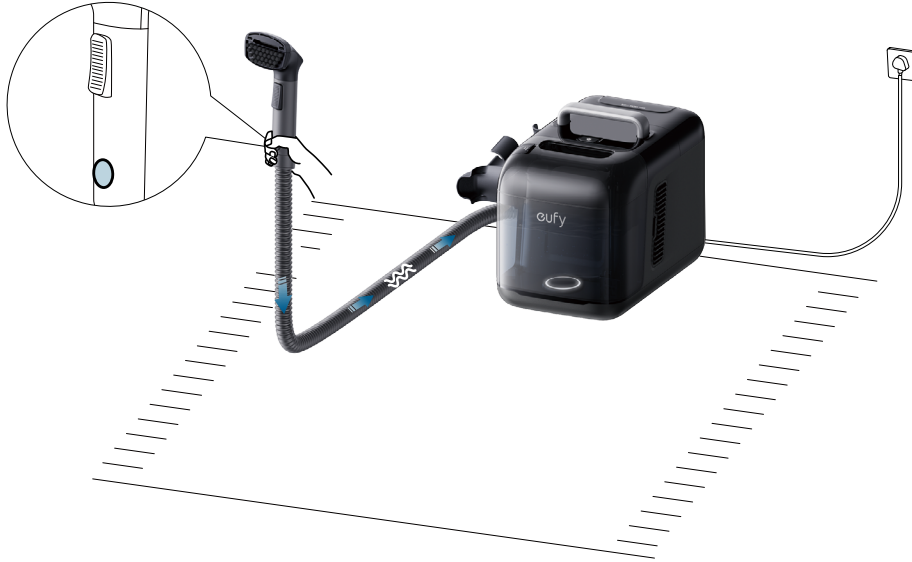

- 💡 • The self-cleaning process will take 5 seconds. During this process, ensure the brush is in an upright position.

### 7.4 After Use

1. Unplug the cleaner. Wind the hose around the cleaner in two tidy loops, then firmly secure the nozzle into the slot.



- 💡 • Ensure not to wrap the hose too tightly, as this could cause it to deform and prevent the cover of Portable Deep Cleaner from closing properly.

2. Gently place the cleaner back on the station, and place the cover on and ensure it is securely positioned in the slot.



- 💡 • When the Portable Deep Cleaner is back in the station, remember to connect the Omni Station to a power source so that RoboVac can function normally in subsequent use.

## 8. Cleaning and Maintenance

Prior to cleaning and maintaining, power off the device and unplug the power adapter. Any other servicing should be performed by an authorized service representative.

For optimal performance, follow the instructions below to clean and maintain E28 regularly. The cleaning and replacement frequency will depend on your usage habits.

### Recommended Cleaning and Replacement Frequency

Components	Cleaning Frequency	Replacement Frequency
Dustbin	Once a week	-
Large Filter of Dirty Water Reservoir	Once a month	-
Filter Valve Assembly	-	Every 6 months
Dirty Water Tank of Omni Station	Empty and clean once a week (or when full)	-
Dustbag	-	Every 3 months (or when prompted)
Cleaning Tray	Every 2 weeks	-
Mopping Roller	-	Every 3-6 months
Filter	Once a week	Every 3-6 months
Side Brush	Once a month	Every 3-6 months (or when visibly worn)
Brush Guard	Once a month	Every 3-6 months (or when visibly worn)
Rolling Brush	Once a month	Every 6 months
Sensors	Once a month	-
Charging Pins	Once a month	-
Swivel Wheel	Once a month	-

## 8.1 Clean the Dustbin and Filter

- 1 Open the top cover and take out the Dustbin.
- 2 Pull the release latch to open the cover. Take out the filter.
- 3 Empty the dustbin.
- 4 Tap the filter to remove dust.
- 5 Rinse the Dustbin and filter thoroughly with water.
- 6 Air-dry the Dustbin and filter completely before next use.
- 7 Place the filter back into the Dustbin.
- 8 Push the Dustbin back into the main unit.



1

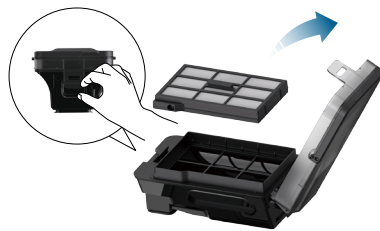

2



3



4



5



6



7



8

- Do not use the filter if it is not completely dry, otherwise it may affect the cleaning performance.
- Do not use a brush, hot water, or any detergent to clean the filter.

## 8.2 Clean the Rolling Brush

- 1 Push the release tabs to unlock the brush guard.
- 2 Push the side of one rolling brush inward and gently flip it up.
- 3 Gently twist and pull out the rolling brush.
- 4 Push the side of the other rolling brush inward and gently flip it up.
- 5 Gently twist and pull out the other rolling brush.
- 6 Rinse both rolling brushes and brush guard with running water. Air dry the rolling brushes and brush guard completely before next use.
- 7 Reinstall one side of the rolling brush and snap it into place.
- 8 Reinstall the other side of the rolling brush and snap it into place.
- 9 Press down to snap the brush guard into place.

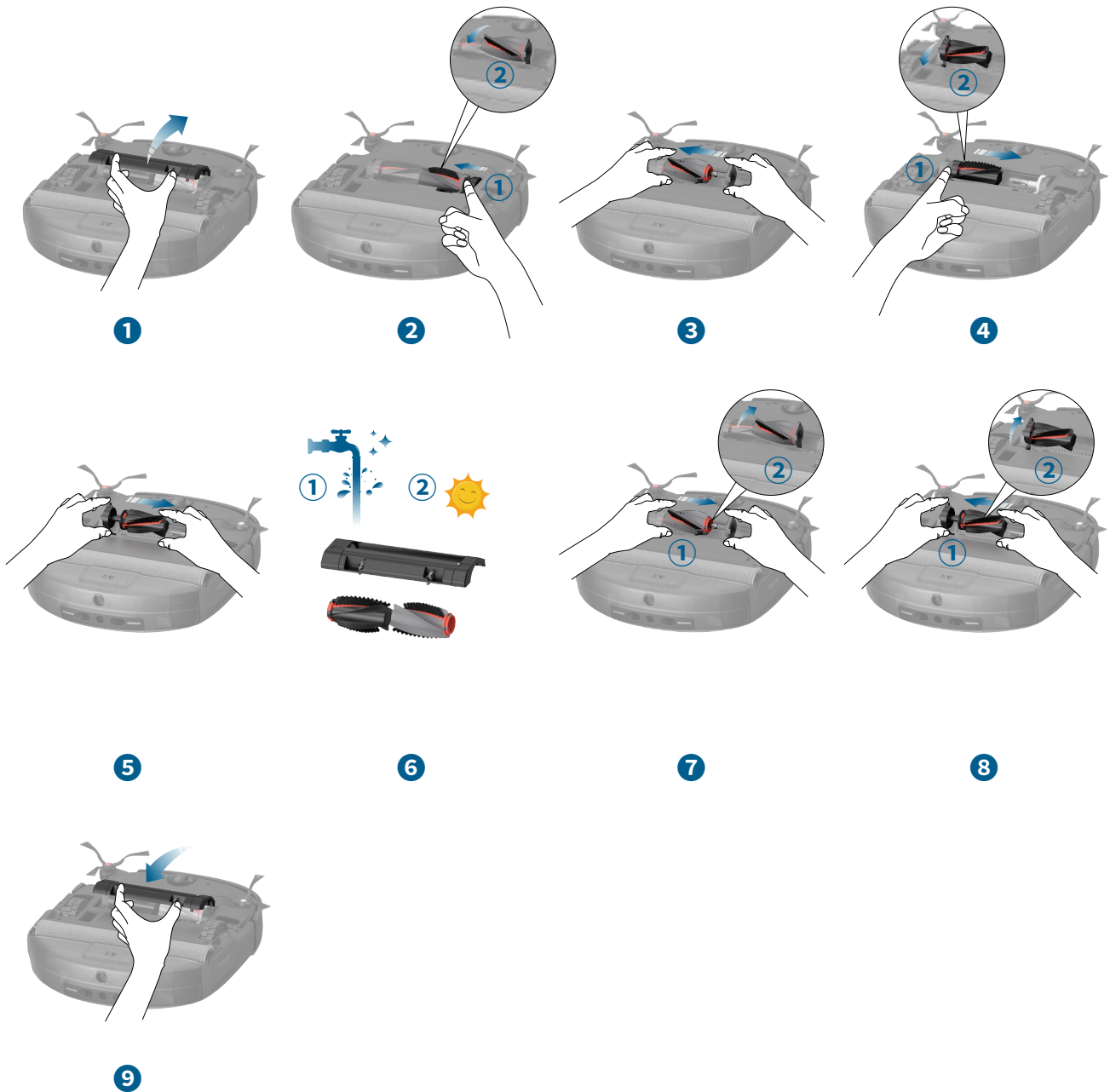

### 8.3 Clean the Side Brush and CornerRover Arm

Foreign substances, such as hair, can easily get tangled in the side brush and CornerRover Arm, so it is best to clean them regularly.

- 1 Remove the side brush.
- 2 Carefully unwind and pull off any hair or substances attached to the side brush and CornerRover Arm.
- 3 Clean the side brush with water.
- 4 Air dry the side brush before next use.
- 5 Reinstall the side brush on the machine.

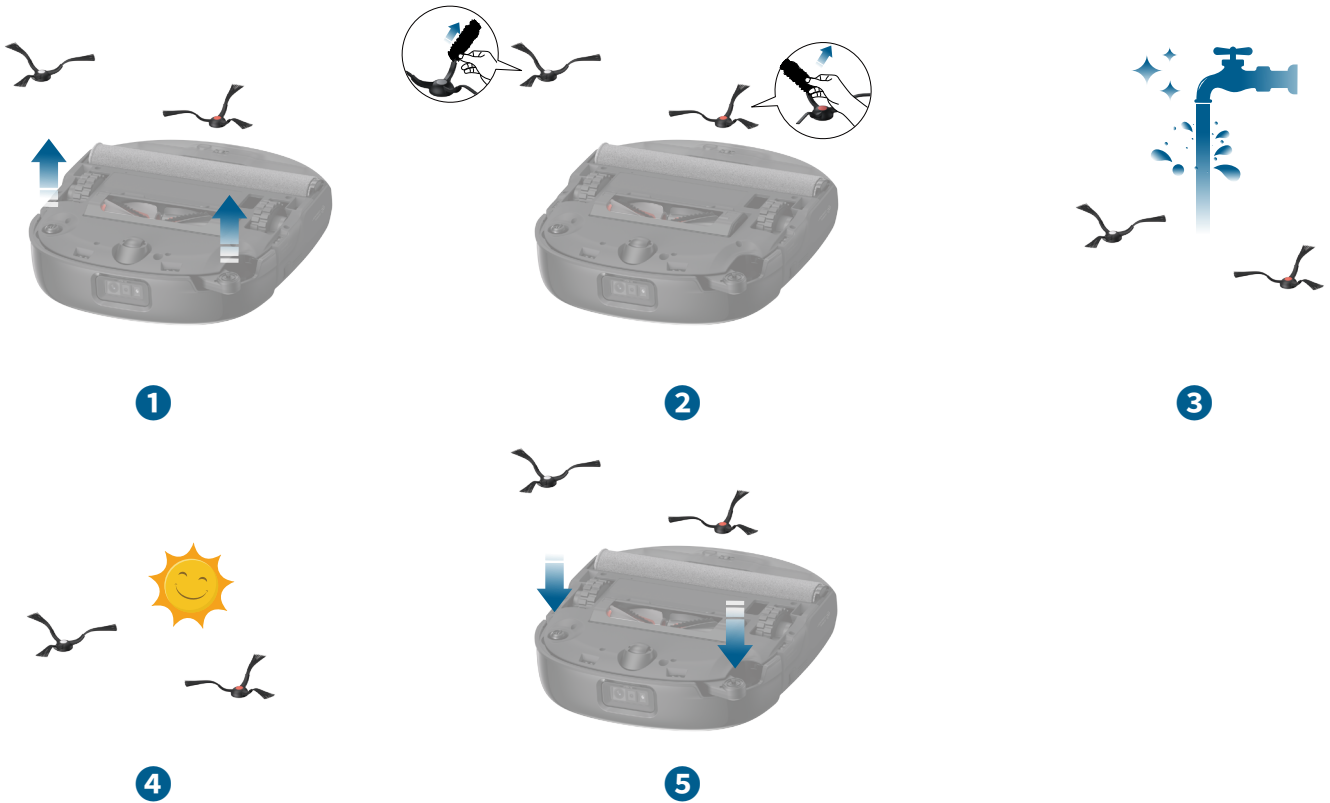

### 8.4 Clean the Sensors, Cameras, and Charging Pins

To maintain the best performance, clean the sensors and charging contact pins regularly.

- Dust off the sensors and charging contact pins using a soft cloth.



## 8.5 Clean the Dirty Water Tank

- 1 Remove the dirty water tank from the Omni Station.
- 2 Empty the dirty water tank.
- 3 Rinse the dirty water tank thoroughly with running water.



1



2



3

## 8.6 Clean the Cleaning Tray

- 1 Remove the cleaning tray from the Omni Station.
- 2 Rinse the cleaning tray thoroughly with water, and clean it with a brush.
- 3 Place it back into the Omni Station.



1



2





3

## 9. Troubleshooting

When an error occurs, please refer to the in-app instructions for solutions. If the problem persists, please contact [support@eufy.com](mailto:support@eufy.com) for help.

## 10. Specifications

	Model name	T2352
	Dimensions	346*327*111mm
	Weight	11.46 lb
	Battery	Li-ion 5200mAh DC14.6
	Input	20V=1.8A
	Maximum output power	60 W
	Normal operating output power	55 W
	Charging Time	3.5h
	Clean Water Tank	120ml
	Dirty Water Tank	180ml
	Model name	T2352
	Dimensions	371.5*484*464mm
	Weight	21.38 lb
	Input	US/JP/KR/CA Version: 100-127V, 50-60Hz; EU/UK/AU/MEA Version: 220-240V, 50-60Hz;
	Power (Dry and charge)	130W
	Power (Dust Collection)	900W Max
	Power of Portable Deep Cleaner	EU /AU /KR Version: 450W, 400W (during water suction) US / JP Version: 400W, 400W (during water suction)
	Clean Water Tank	2.5L
	Dirty Water Tank	1.8L

 • As voltages vary across different countries and regions, we recommend purchasing the machine version specific to your location to avoid potential safety hazards and equipment damage.

## 11. Customer Service

Contact Us:



support@eufy.com



www.eufy.com



(US/CA) +1 (800)994 3056

(UK) +44 (0) 1604 936 200

(DE) +49 (0) 69 9579 7960

(JP) +81 03 4455 7823

For video tutorials, FAQs, warranty policies, and more information, please visit <https://support.eufy.com/>

Hereby, Anker Innovations Limited declares that this device is in compliance with The Product Security and Telecommunications Infrastructure (Security Requirements for Relevant Connectable Products) Regulations 2023. For the Statement of Compliance, visit the website: <https://www.eufy.com/uk/psti-related>.

A. the equipment does not have a standby mode or other equivalent state in terms of energy efficiency requirements, power management function or the ability to deactivate wireless network connections mode;  
B. the power consumption of the equipment is likely to be higher than other equipment models meeting these functional requirements.

1. Power consumption in standby mode:  $\leq 0.5$  W
2. Power consumption in standby mode with Display:  $\leq 0.8$  W
3. Power consumption in networked standby mode:  $\leq 2$  W
4. Power management:  $\leq 20$  min