

iQ700, Integrated Design Hood, 60 cm, clear glass black printed, Matt black LJ68BET60B



- ✓ Matt finish: Modern matt coating with fewer visible fingerprints.
- ✓ Maximum storage space: T-shaped hood allows storage weight of up to 10kg on each side.
- ✓ iQdrive motor: Strong suction power, quiet performance, and long-lasting durability.
- ✓ Intelligent hood automatic: Automatically adjusts extraction based on air quality and hob activity.
- ✓ touchControl Plus: Precise control directly on the hood's glass panel.

Optional accessories

LZ11IBJ16	Long-life Clean Air recirculation kit
LZ11IBK62	Chimney extension 450-854 mm
LZ11IBN62	Chimney extension 187-360 mm

Features

Technical Data

Typology:	Built-in/Built-under
Length electrical supply cord:	130 cm
Required niche size for installation (HxWxD):	340mm x 560.0mm x 300mm mm
Height of the appliance:	60 mm
Minimum distance above an electric hob:	430 mm
Minimum distance above a gas hob:	650 mm
Weight:	9.1 kg
Control panel:	Electronic
Number of speed settings:	3-stage + 2 intensive
Maximum output air extraction:	427 m³/h
Boost position output recirculating:	656.0 m³/h
Maximum output recirculating air:	414 m³/h
Boost position air extraction:	851 m³/h
Maximum Air flow:	427 m³/h
Number of lights:	2
Noise level:	57 dB(A) re 1pW
Diameter of air outlet:	150 mm
Grease filter material:	Washable stainless steel
EAN code:	4242003976425
Connection Rating:	200 W
Nominal power:	220-240 V
Frequency:	50; 60 Hz
Plug type:	GB plug
Installation type:	Built-in



iQ700, Integrated Design Hood, 60 cm, clear glass black printed, Matt black LJ68BET60B

Features

Design:

- Installation in a wall cupboard
- Flush-fitted installation for a seamless integration in wall cupboards.
- Glass panel: clear glass black printed
- Enlarged storage space: max. 10 kg capacity on each hood side
- Suitable for ducted and re-circulating operation

Core Features:

- Efficient BLDC motor
- 2 x LED 3W with Colour temperature adjustable
- softLight with dimmer function : the lighting elements switch on and off smoothly.
- softLight with dimmer function : the brightness of the lighting elements can be adjusted.
- Colour Temperature: 3500 K
- Light Intensity: 437 lux
- 2 metal grease filter(s).

Comfort Features:

- climateControl sensor: Automatic Sensor-based performance control for best results
- Glass panel with touch control for an easy operation and enhanced vapor capture.
- Cupboard protection: additional side and rear protection against vapour
- Extraction and lighting are automatically turned on and off by opening and closing the glass panel.
- Lighting can also be turned on and off when the glass panel is closed by quick hand touch on control panel.
- touchControl Plus backlighted
- 3 power levels and 2 intensive settings
- Saturation indicator for grease filter
- Automatic reset from intensive to normal setting after 6 min
- Automatic after running (10 minutes)

Digital Features:

- Home Connect: operate, monitor and set preferences of your hood via smartphone or tablet (only in countries where Home Connect service is available)
- cookConnect hob based hood control: automatically activates the hood when cooking, thanks to the WiFi connection of hood and suitable hob.
- Intelligent hood automatic with sensor: fully automatic hood performance combining hob-provided cooking data and sensor-detected cooking data (works with all current induction hobs with touchSlider; for other Home Connect hobs, the hood can be controlled directly from the hob, provided a connected Home Connect account is available)
- Voice Control enabled via popular voice assistants (only in countries where this service is available)
- Performance Profiles: choose between standard, performance or silence profiles to increase the extraction rate or reduce the fan noise

via Home Connect App

- Favourite Button: directly access favourite functions with a configurable button (available with connected Home Connect account).
- Smart home trigger, via Favourite button (available with connected Home Connect account): open up the smart universe from your hood (partner service required).
- LED light with adjustable light temperature: Allows you to adapt the light temperature to your personal needs via Home Connect App
- Saturation indicator, set and reset function for grease filter and odor filter available via Home Connect app.
- After run function: available via Home Connect App
- Interval function: available via Home Connect App
- The Home Connect functionality can be extended by integrating numerous applications from external cooperation partners (partnerships)
- Updateable appliance (available with connected Home Connect account): keep appliance always up to date with latest status of software.

Cleaning Comfort:

- Easy to clean smooth surfaces and materials.
- Steel filter cover dishwasher-safe
- Coated surfaces for less fingerprint sensitivity

Exhaust Mode:

- According to EN 61591 and EN/ IEC 60704-2-13 your appliance can achieve the following values in exhaust mode: Speed 1: extraction rate 241 m3/h ; noise level 42 dB (A) re1pW Speed 2: extraction rate 335 m3/h ; noise level 50 dB (A) re1pW Speed 3: extraction rate 427 m3/h ; noise level 57 dB (A) re1pW Intensive 1: extraction rate 693 m3/h ; noise level 69 dB (A) re1pW Intensive 2: extraction rate 851 m3/h; noise level 73 dB (A) re1pW
- Energy Efficiency Class: A+ (at a range of energy efficiency classes from A+++ to D)
- Average Energy Consumption: 35.3 kWh/year*
- Blower Efficiency Class: A*
- Lighting Efficiency Class: A*
- Grease Filtering Efficiency Class: B*

Recirculation Mode:

- For recirculation operation Long-life Clean Air recirculation kit (accessory) needed
- The Long-life Clean Air odour filter absorbs intense odours, such as fish, as well as pollen. The lifetime can be extended up to 4 times by refreshing the filter in the oven
- According to EN 61591 and EN/ IEC 60704-2-13 your appliance can achieve the following values in recirculation mode with Long-life Clean Air recirculation kit (available as optional accessory):
- Speed 1: extraction rate 231 m3/h; noise level 53 dB(A) re1pW
- Speed 2: extraction rate 328 m3/h; noise level 61 dB(A) re1pW
- Speed 3: extraction rate 414 m3/h; noise level 66 dB(A) re1pW
- Intensive Speed 1: extraction rate 584 m3/h; noise level 73 dB(A)

Features

re1pW

- Intensive Speed 2: extraction rate 656 m³/h; noise level 76 dB (A)

re1pW

Technical Information and Sustainability:

- Consumption data:
- Power rating: 200 W
- Voltage: Nominal voltage: 220 - 240 V
- Sustainability:
- Made in Germany: produced at a CO₂ neutral production site
- Environmentally friendly packaging
- Most efficient blower technology available on the market
- Available Long-life Clean Air odour filter with extended lifetime up to 4 times
- climateControl sensor: Sensor-based performance control for best results with minimum energy consumption.

Planning and Installation Information:

- Installation: Cupboard 60 cm
- Installation system: IDH comfort installation
- Appliance dimensions (HxWxD): 340 x 598 x 298 mm
- Built-in dimensions (HxWxD): min. 340 mm x 560 mm x min. 300 mm
- Enclosed spacers for installation in wall cupboards with maximum depth of up to 360mm.
- For installation in higher wall cupboards chimney extensions are available as optional accessories.
- Diameter pipe Ø 150 mm
- Electrical cable length 1.3 m

Features

--	--

Dimensioned drawings

Measurements in mm
Installation example with spice rack

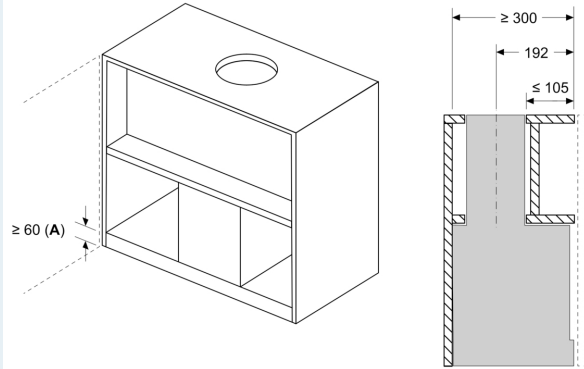

A: Area without hinges

Installation example in cupboards with crossbar, if installation with chimney extension (other accessories) not possible

Measurements in mm
Installation example in furniture cut-out

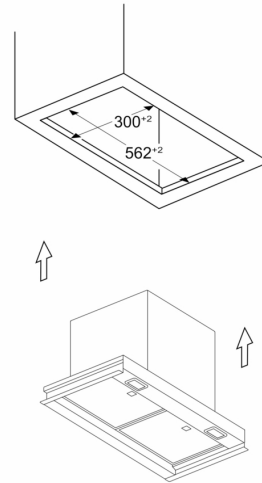

Measurements in mm
Installation requirements for replacement business

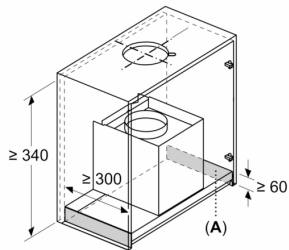

A: Area without hinges

Installation requirements for replacing existing built-in hood solutions with integrated design hood without replacing the cupboard

Measurements in mm
Side view

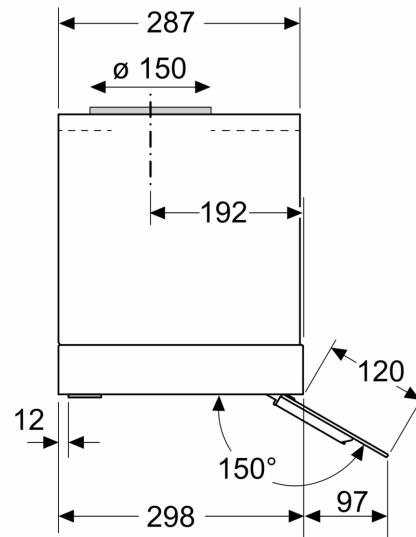

Dimensioned drawings

Measurements in mm

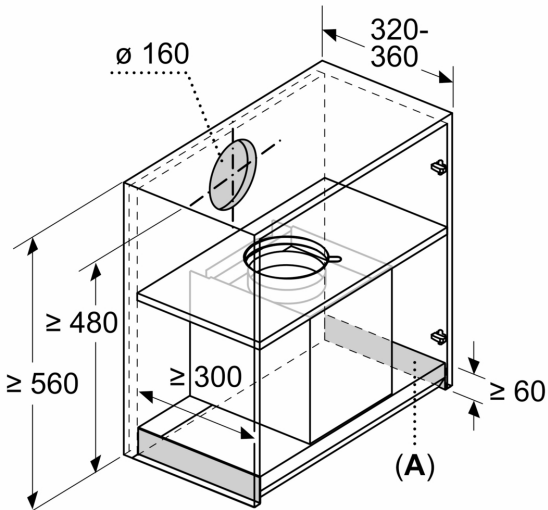

A: Area without hinges