

Gri||stream®

Built In 6 Burner Barbecue GBI66SS

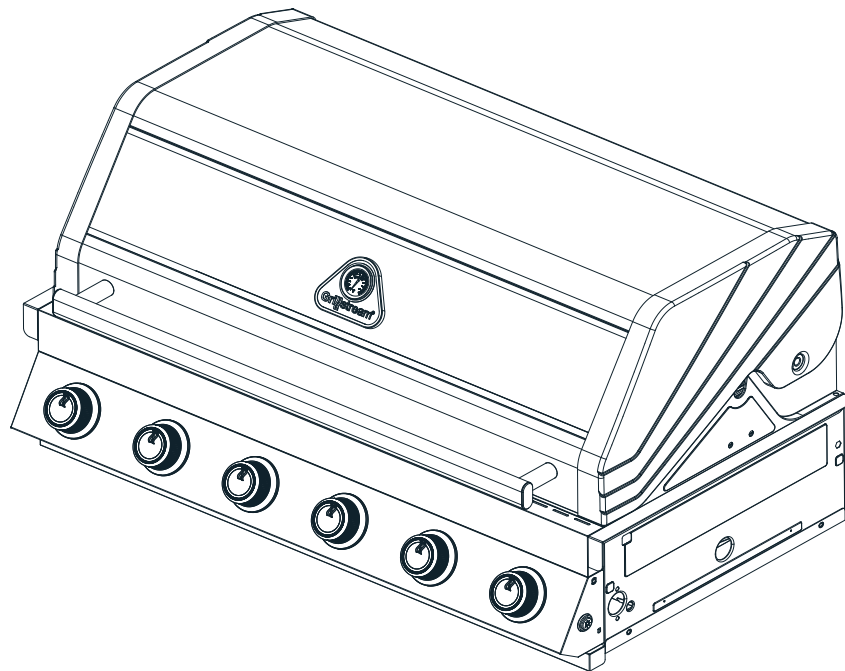

WARNING! FOR YOUR SAFETY, FOR OUTDOOR USE ONLY

Please read these instructions carefully and ensure that your barbecue is properly installed, assembled, maintained and serviced in accordance with these instructions.

Failure to follow these instructions may result in serious injury and/or damage to property.

Necessary Tools



X4
AA Battery
(Not included)

Please check the pack contents before attempting to assemble this product. A full checklist of components is given in this leaflet. If any components are missing, please contact the retailer from whom you bought this product.

This product takes approximately **20 MINUTES** to assemble with **2 PEOPLE**. The fittings pack contains **SMALL ITEMS** which should be **KEPT AWAY FROM YOUNG CHILDREN**. Read this leaflet in full before commencing assembly.



Carbon Monoxide Hazard

Using a barbecue inside can kill you, it gives off Carbon Monoxide, which has no odour. Never use a barbecue in enclosed spaces such as a tent, home/building, vehicle or garage.

Contents

Warning Information	Page	3
Location of your BBQ	Page	3
Connecting to the gas cylinder	Page	3
The hose and regulator assembly	Page	3
Testing for leaks	Page	4
Gas cylinder safety	Page	4
What is Propane	Page	4
Are all gas bottle gases the same	Page	4
How is it different from natural gas	Page	4
Lighting your BBQ	Page	5
Using your BBQ	Page	5
Hybrid System	Page	6
Maintenance of your BBQ	Page	7
Troubleshooting	Page	8
Warranty	Page	8
Exploded diagram	Page	9
Parts list	Page	10
Fittings list	Page	11
Assembly instructions	Page	12-18
Leak Test	Page	19

⚠ WARNING INFORMATION

- Read this Operating Manual before use.
- Ensure there is adequate clearance away from flammable materials.
- Please do not use in windy conditions as flame efficiency may be affected and could cause excessive heat on the front panel.
- This BBQ is only to be used outdoors.
- Do not allow children to operate the BBQ.
- Accessible parts may be very hot, keep children away. Even after turning off, BBQ will remain hot.
- Any modification of this BBQ may be dangerous.
- Do not move this BBQ during use.
- When you have finished cooking, turn off the gas cylinder before you turn off the BBQ controls to ensure any gas in the pipeline is used up.
- Parts sealed by the manufacturer or their agent must not be manipulated by the user.
- BBQ specifications can be found on the data label attached on the side panel of the BBQ frame.
- Do not store or use petrol or other flammable vapours and liquids near the BBQ.
- Do not store empty or full spare gas cylinders under or near the BBQ.
- Keep the gas hose and any electrical cord away from hot surfaces.
- Ensure that all packaging is removed from within the BBQ before use, including protective films. And all cable ties securing the gas hose to the underside of the BBQ are removed too.
- Avoid unnecessary twisting of the gas hose.
- Visually inspect hose prior to each use for cuts, cracks, excessive wear or other damage.
- The hose must be replaced if damaged and when National Conditions require it.
- Never light the BBQ with the hood or lid closed.
- Never lean over the cooking surface whilst lighting the BBQ.
- Use BBQ tools with heat proof handles or good quality insulated oven mitts when operating BBQ.
- Never alter or modify the regulator or gas supply assembly.

LOCATION OF YOUR BBQ

IMPORTANT - BBQS MUST BE INSTALLED IN ACCORDANCE WITH THE MANUFACTURER'S INSTALLATION INSTRUCTIONS, LOCAL GAS FITTING REGULATIONS AND MUNICIPAL BUILDING CODES.

Think carefully when deciding on a location where you are to use your BBQ. The BBQ must not be installed under or on any combustible material and must be a level surface. Minimum clearance from any combustible materials on ALL sides is 430mm (18"). Minimum clearance from any combustible material from the TOP of the BBQ is 1000mm (39"). (Fig. 1)

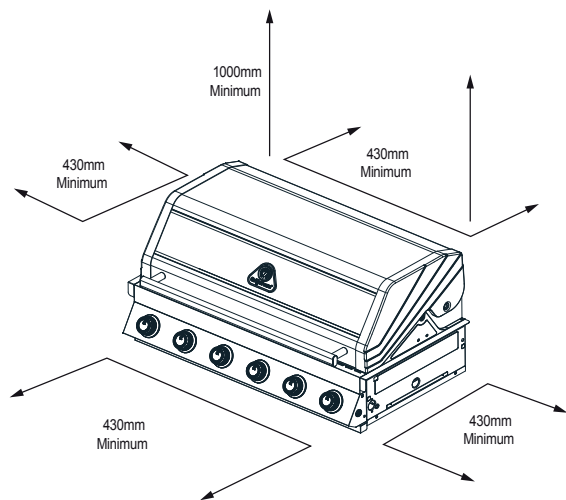

- Not to be used in garages, porches, breezeways, sheds, or other enclosed areas
- Not to be used on recreational vehicles
- Do not obstruct flow of combustion and ventilation air around the BBQ

CONNECTING THE GAS CYLINDER

There are two different types of gas that can be used on your gas BBQ depending on where you live, that being either butane or propane gas. Both are supplied in gas cylinders. The connection between the gas cylinder and the BBQ is made with a regulator. (Fig. 2)

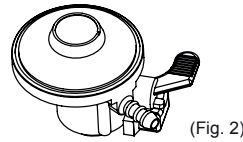

It is important that you use the correct regulator for the particular type of gas you purchase. See your local gas dealer for information on purchasing the correct regulator. Never operate this BBQ without a gas regulator.

The following gas supply pressures are a guide only:

For (DK) (FI) (NO) (NL) (SE) (HR) (SI) (IS) (EE) (LV)

Butane - 30 millibars } 1 3 B/P (30)
 Propane - 30 millibars }

For (GB) (IE) (BE) (FR) (GR) (IT) (ES) (LU) (PT) (CH) (CZ)

Butane - 28 millibars } 1 3 + (28 - 30/37)
 Propane - 37 millibars }

For (DE) (AT)

Butane - 50 millibars } 1 3 B/P (50)
 Propane - 50 millibars }

FOR AUSTRALIA
 Propane - 2.75 kPa
 Universal LPG - 2.75 kPa

GRILLSTREAM BARBECUES, LEISUREGROW PRODUCTS LTD.		UK CA 0359-24	CE 2575-24
Product name	Outdoor gas Grill		
Model Number	K1065B8D15Y-1		
Gas Category	<input checked="" type="checkbox"/> 1-1065B8D15Y-1	<input type="checkbox"/> 1-1065B8D15Y-2	<input type="checkbox"/> 1-1065B8D15Y-3
Gas and Supply Pressure	Butane(G30)	Propane(G31)	Butane
	28-30 mbar	37 mbar	29 mbar 37 mbar 50 mbar
Country of Destination	1-1065B8D15Y-1: BE,CH,CY,CZ,ES,FR,GB,GR,IE,IT,LT,LU,LV,PT,SK,SI; 1-1065B8D15Y-2: CY,CZ,DK,EE,FI,FR,HU,LT,IT,NO,NL,SE,SI,SK,RO,HR,TR,BG,IS,LU,MT; 1-1065B8D15Y-3: AT,CH,CZ,DE,SK; 1-1065B8D15Y-4: PL		
Main Burner Injector Size	Ø 0.92 mm	Ø 0.92 mm	Ø 0.86 mm Ø 0.81 mm
Side Burner Injector Size	Ø 0.92 mm	Ø 0.92 mm	Ø 0.86 mm Ø 0.81 mm
Total Nominal Heat Inputs (Hs)	24.5kW(1781g/h)		
Electric energy(V/DC)	4X1.5V-LED lamp/App Thermometer; 1X1.5V- Infrared Side Burner Ignition		
Serial Number			
Use Outdoors Only .			
Read the instructions before using the appliance.			
Warning : Accessible parts may be very hot. Keep young children away.			
Made in China			

THE HOSE AND REGULATOR ASSEMBLY

- Must be suitable for liquefied petroleum gas (LPG)
- Must withstand the above pressures
- Must not exceed 1000mm (39") in length
- The BBQ is supplied with a quick release hose that is suitable for direct connection of a suitable regulator
- Before connecting inspect the hose, its fittings and rubber seals. If there is any sign of cracking, splitting or wear, have the hose replaced
- While in use, keep the hose unobstructed and free of kinks and twisting

SECURING THE HOSE AND REGULATOR ASSEMBLY

Quick release connection (Fig. 4)

- The BBQ's manifold connection is a quick release connector
- Gently pull back the movable section on the manifold, insert hose and release. Reverse the process to remove.
- Check connection is secure and test for a gas leak before using.

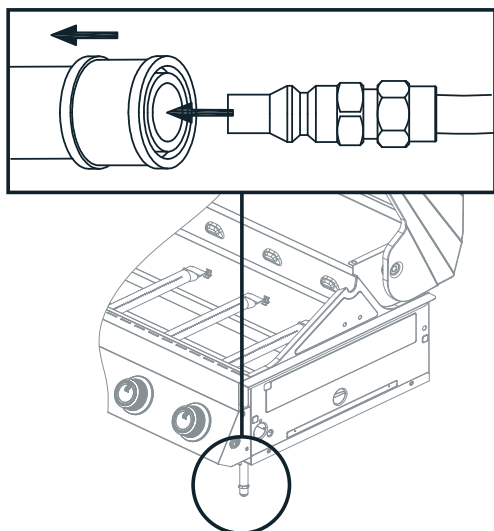

TESTING FOR LEAKS - DO THIS BEFORE USING YOUR BBQ

NOTE - DO NOT test for gas leaks with an open flame. If you smell gas, turn off at the source.

- Before first use and periodically during the season, or whenever a gas cylinder is changed, you must check for gas leaks.

Do so by:

- Turn on the gas cylinder
- Turn all gas valves on the BBQ to the • **off** position
- Brush a soap solution of one part liquid detergent and one part water to all gas connections
- The presence of bubbles indicates a leak. Tighten or repair as necessary
- Under no circumstances should a naked flame be used to check for leaks
- If a gas odour is present and no leaks can be found, do not use the BBQ. Turn the gas off at the source, disconnect the hose and immediately contact your BBQ dealer or place of purchase for assistance.

Further illustration of this is available in the "testing your BBQ" section of this manual and also in your Time to Grill user manual included with your BBQ. For our video tutorial please scan this QR code to access.



GAS CYLINDER SAFETY

- Always change over a gas cylinder away from any possible source of ignition in a well ventilated area
- Do not smoke whilst handling gas cylinders
- Never store gas cylinder indoors
- Store away from direct heat in a well ventilated area
- The gas cylinder is position on a flat surface
- Always keep the gas cylinder in an upright position
- Close cylinder valve when BBQ is not in use and, if available, use a sealing plug to prevent possible leaks
- Do not subject gas cylinder to excessive heat
- Do not tamper with any fitting attached to any gas cylinder. Have it taken to the manufacturer or an authorized testing station
- When the cylinder runs out of gas, have it refilled or swapped at an authorized testing station. They will fill the cylinder to no more than 80% of its capacity. This allows the gas to expand with temperatures
- Have the cylinder inspected EVERY 10 YEARS at an authorized testing station.

WHAT IS PROPANE

It is a fuel gas compressed until it turns to liquid, then stored in a bottle or cylinder under pressure for easy transport.

ARE ALL GAS BOTTLE GASES THE SAME?

No. The LPG that cars use is known as auto LPG. It is different to propane/butane, which is used in household gas appliances. This guide only deals with propane/butane.

HOW IS IT DIFFERENT FROM NATURAL GAS?

Propane and butane are similar to natural gas. They are colorless, non-poisonous and do not pollute when burnt. There is one important difference, propane and butane are heavier than air, if they escape they don't float away. The gas collects and forms gas pools at ground level or at the bottom of your appliance.

LIGHTING YOUR BBQ

JET FLAME IGNITION SYSTEM

Upon turning any burner control knob you will hear an audible "click". This is known as a Jet Flame Ignition System.

Jet Flame Ignition to ALL burners

- Before starting - ALL burner control knobs must be in the • **off** position
- Flat lids and roasting hoods must be OPEN before lighting
- Turn on the gas cylinder
- Push in and turn **Any Knob** in an anti-clockwise direction to the **hi** position or until a click is heard. This will trigger a spark to light the burner.
- If burner does not light immediately, turn the gas control knob to the • **off** position and wait five minutes for any accumulated gas to clear out of the BBQ before repeating procedure.

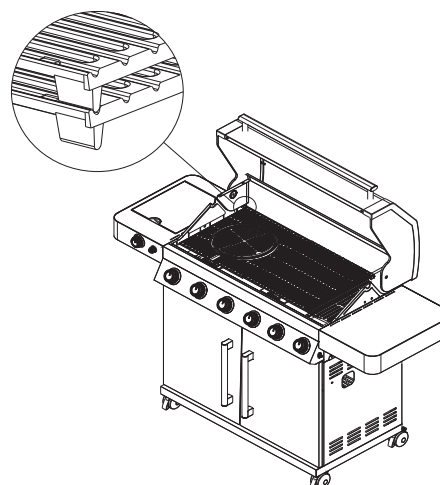

LIGHTING YOUR BBQ (cont.)

- The **lo** position is obtained by turning the knob fully anti-clockwise
- Adjusting the control knob to your heat requirements allows you to control the flame
- If ignition cannot be achieved see section: If BBQ fails to operate properly

IMPORTANT - It is important that all control valves, and the gas cylinder are turned off after use.

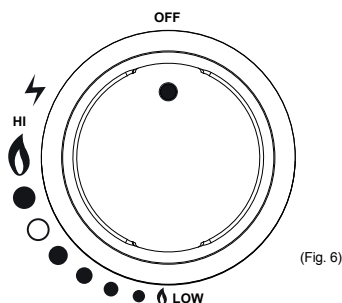

USING YOUR BBQ

GRILL AND FLAME TAMER PLACEMENT

- The flame tamer should be placed underneath the grill
- Order of how things go into the barbecue:
1. Oil channel inserted into front of frame with end of channel going through hole. (Fig 8)
 2. Grillstream Grills always go to the left hand sides.
 3. Griddles are always on the right.

NOTE:

- a. Ensure that your grills incline from front to back to the fat collecting channel at the front of the barbecue.
- b. There may be a slight movement in the grill bars while cooking, this is normal and will not affect the way the Grillstream system works.

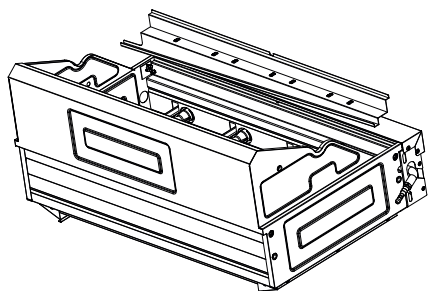

(Fig.8)

Grillstream Grills fit directly on top of each other - do not offset them.

FIRST TIME USE OF BBQ

- Before using the BBQ for the first time, it should be first wiped with a mild soap and water solution to remove any dust
- Make sure your BBQ is on a solid level surface
- Dry cooking surface and apply a light coating of cooking oil
- Light the barbecue and leave burning for 30 minutes on the **lo** position, with hood up. This is to burn off any residual oils or foreign matter on the grills and hotplates.
- Check burner alignment, for further information, refer to page 8 in troubleshooting.

FAT COLLECTION

Using the fat collection cup

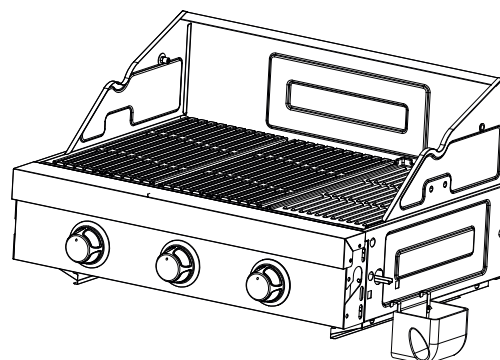

PREHEATING

Light the burners as previously directed, turn to **hi** and allow the BBQ to preheat for 2-5 minutes ensuring the temperature does not exceed 250°C. Adjust control to desired optimum cooking temperature, the hood must be closed while doing this. **EXCEEDING 250 Degrees CAN DAMAGE THE BBQ AND VOID YOUR WARRANTY**

PREPARE THE COOKING SURFACE

We suggest setting your barbecue to a low temperature for 30 minutes with the hood down to allow any residue to burn off, and then carefully brushing the grills with oil. this will create a non stick affect and also help prevent any build up of corrosion.

Note: The flame tamers disperse the heat from the burners. This results in a uniform heat zone beneath the cooking grill.

COOKING WITH THE ROASTING HOOD DOWN

When using the BBQ with the hood closed, irrespective of the heat source (gas or charcoal), **exceeding 250°C can damage the BBQ and void your warranty.**

GRILLSTREAM HYBRID SYSTEM

This Grillstream Barbecue comes equipped with the revolutionary Grillstream Hybrid System enabling you to cook with gas, charcoal or both!

DIRECTIONS FOR USE - CHARCOAL:

For best results use **Charcoal Briquettes**. We would always recommend using Charcoal Briquettes for a longer, more even heat output. Please note the hybrid system is not designed to be used with lava rock, as lava rock is not an independent heat source like charcoal.

STEP 1:

Remove your Grillstream Grills and load the Grillstream Hybrid System Charcoal Trays with charcoal. If using Charcoal Briquettes load a single layer, stood up on end (as illustrated) to allow optimal loading. Place your Grillstream Grills back into position. It is important that the Charcoal Trays are not overloaded with charcoal – if charcoal is in contact with the Grillstream Grills please remove some until there is approximately a 1cm gap between charcoal and grill. Failure to do this could lead to excessive heat and a sub-optimal cooking experience or even damage to your barbecue.

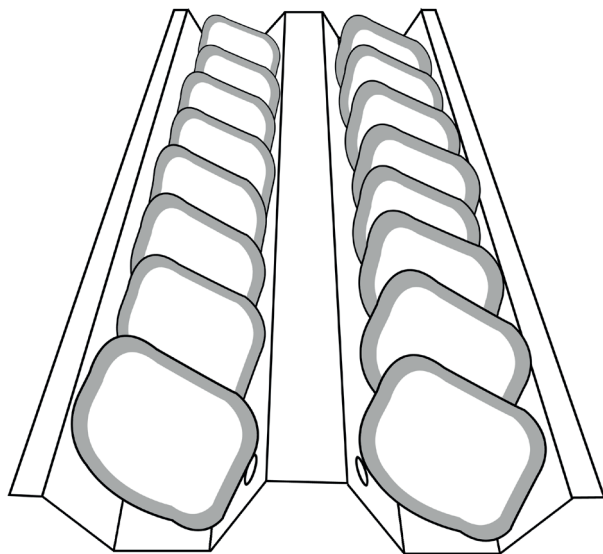

STEP 2:

With the Barbecue Hood open, light the burners located below the Charcoal Trays and leave on maximum for 10 minutes. Leave your Barbecue Hood open to aid oxygen flow and accelerate the lighting process. Please note: **DO NOT** use Lighter Fluid, Lighter Gel, Paraffin Cubes or any other type of lighting aid.

STEP 3:

Your charcoal should now be lit and making the tell-tale popping and cracking sounds that indicate this. You should now turn off the burners completely and close your Barbecue Hood.

STEP 4:

To avoid burning your food it is always recommended that you wait for the charcoal to become coated by a layer of white ash before commencing cooking. This is usually around 20-30 minutes after first lighting the charcoal but this can vary depending on weather

conditions and placement of the Barbecue.

If you have followed the above instructions you will now have at least 1 hour of cooking time before needing to top-up the charcoal or relighting the burners and using the Barbecue as a standard gas model. When adding additional charcoal please be aware the grills will be very hot and require careful removal using the Grill Lifters supplied with this BBQ. We would also recommend using heat-resistant BBQ

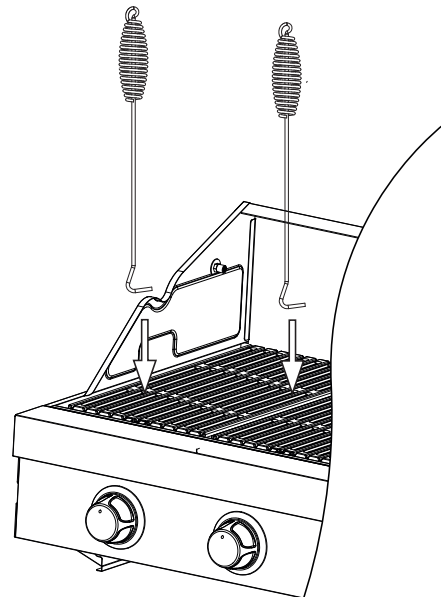

- Hook Grill Lifters at opposite corners of the grill.

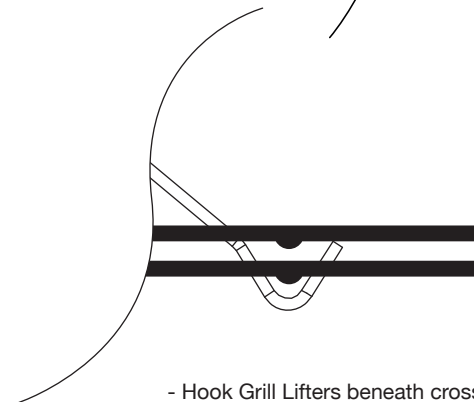

- Hook Grill Lifters beneath cross bar section of both grills.

Gloves (sold separately) when removing the hot grills. Once you have finished cooking and have allowed adequate time for the Barbecue to completely cool down, you should carefully dispose of the Ash that will have collected in the Charcoal Trays and the Grease Tray. This ash should be emptied after every use.

DIRECTIONS FOR USE - GAS:

The beauty of the Grillstream Hybrid System is that there is no additional assembly or conversion process required, whether you want to use it as a Charcoal Barbecue or Gas Barbecue. If you have set the Barbecue up, as per the Assembly Instructions, you are ready to cook with Gas. **YOU SHOULD NOT** remove the Grillstream Hybrid System Charcoal Trays as these function as heat diffusers when using Gas, ensuring even heat distribution.

MAINTENANCE OF YOUR BBQ

PROTECTION

Keep your BBQ beneath a weather cover and out of the rain. Proper care and maintenance will keep your BBQ in top operating condition and prolong its life.

CLEANING THE COOKING SURFACES

Allow your BBQ to continue burning for 5 minutes after cooking has ceased, which will burn off excess fats and juices etc. that may block the flame ports of the burners. To keep your BBQ ready for the next time, turn the burners to **off** then take a long handled brush and brush the cooking surface to remove excess oils and food scraps. Be careful as surfaces are hot. Protect your hands by using an oven mitt to hold the brush.

Allow to cool before washing in a warm soapy solution. Ensure that any dried fat/food deposits are cleaned off both the top and bottom grills after EVERY cooking session to allow fat to stream away efficiently on your next cooking session. To clean the Grills effectively use the Grillstream cleaning brush which has been specially designed to quickly and effectively clean your Grillstream Grills. Rinse off with clean water and dry before returning to BBQ.

CLEANING THE FLAME TAMERS

Periodically wash in a warm soapy solution. Use a wire brush to remove stubborn burnt on cooking residue if necessary. Dry thoroughly before re-installing to the BBQ body.

CLEANING THE BBQ BODY

The body of the BBQ should be cleaned regularly dependant on the use and type of food cooked. Use warm soapy solution.

CLEANING THE DRIP TRAY/FAT COLLECTION CUP

- IMPORTANT - the drip tray, Fat Channel and fat collector should be cleaned on a regular basis. If this is ignored, a build up of fats and greases may cause a fire in the BBQ
- Please check the level of waste fat in the fat collection cup regularly while cooking to ensure it does not overflow and dispose of the waste fat responsibly.
- More frequent cleaning may be necessary as usage demands

- FAT FIRES ARE NOT COVERED BY WARRANTY

CLEANING THE BURNERS

Occasionally after long cooking sessions, excess fats, juices and marinades can clog the burners. If so, remove the burners (see removing burners section) for cleaning.

- Clean by washing in hot water and detergent
- Ensure that all burner ports are free from obstruction
- Rinse in water
- Light immediately to prevent rust and corrosion
- Brush lightly with cooking oil if BBQ is not used for an extended period

FIRST USE AFTER LONG PERIODS

At the start of each BBQ season or before using after a long period of time:

- Read this operation manual again thoroughly
- Check all gas valve orifices, burner tubes and connections for obstructions
- Check that all burners are in their correct positions
- Check to see if the gas cylinder is full
- Check for gas leaks using a soapy water solution
- Set burner controls to **off** and connect gas supply
- Ensure all grills and hotplates are clean before use

REMOVING BURNERS - Necessary care to be undertaken

- Make sure the BBQ has been switched off and has completely cooled down
- Ensure all gas control knobs are set to the off position and the gas cylinder has been turned off
- Lift the grill or hotplate off the BBQ

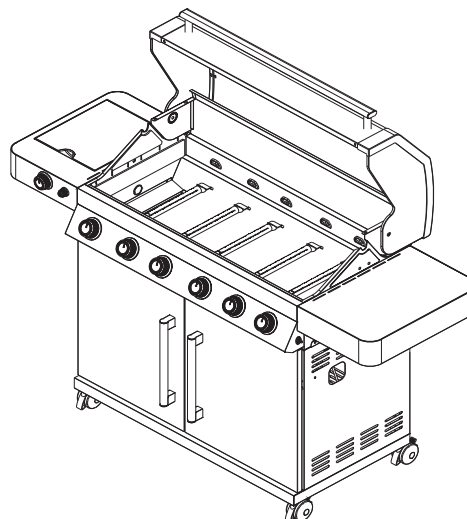

- Remove clip at rear of burner to release the burner

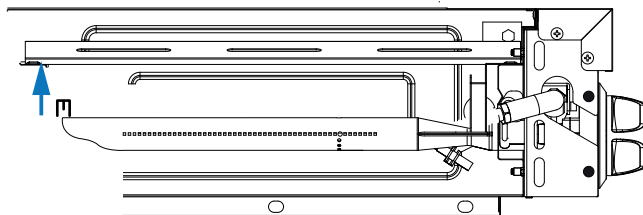

- Remove by twisting and lifting as shown in (Fig. 17)

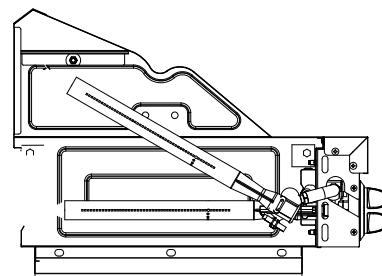

(Fig. 17)

- Clean burners as described
- Reverse the previous procedure to re-install the burners, flame diffuser and grill or hotplate

TROUBLESHOOTING

IF BBQ FAILS TO OPERATE PROPERLY

- Stop, turn off gas at its source and turn all burner controls to • off
- Do not smoke
- Check gas supply connections
- Repeat lighting procedure after waiting for five minutes for accumulated gases to disperse

If BBQ still fails to operate properly **TURN OFF GAS AT SOURCE, TURN BURNER CONTROLS TO OFF**, wait for BBQ to cool and check the following:

- a) **Misalignment of burner tubes over orifices**
CORRECTION: Fig A below shows how it may look if your burner is mis-aligned. Reposition burner tube to properly sit over orifice as shown below in line drawing (fig B). This is also shown in the Time to Grill user manual trouble shooting section (included with your BBQ)
- b) **Obstruction in gas line**
CORRECTION: Remove hose from BBQ. Open gas supply for one second to clear any obstruction from hose. Close off gas supply at source and re-connect hose to BBQ
- c) **Blocked orifice**
CORRECTION: Remove burners as described above. Inspect gas valve orifice, clear any obstruction with a fine wire. Re-install burners over orifices and test again
- d) **Obstructed Jet Flame Ignition tube**
CORRECTION: Insert pipe cleaner or cotton bud into Jet Flame Ignition tube and clear out any debris inside (fig C)

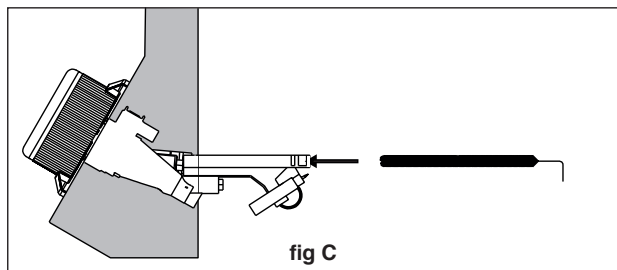
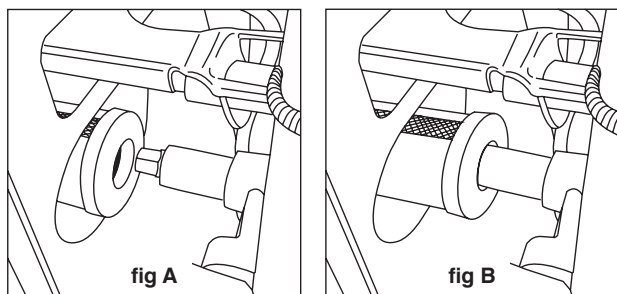

IF THERE IS A LEAK

- Turn the gas cylinder off
- Ventilate the area to disperse any accumulated gas
- Check all connections
- If the leak persists, keep cylinder upright and take to an open area
- Keep skin away from any gas or liquid escaping from the cylinder
- Keep the cylinder at least 20 metres away from any sparks or ignition sources including electrical equipment, camera flash, engines or motors
- Disperse gas by providing maximum ventilation and spraying with a fine water spray

IF THERE IS A FIRE

- If there is a fire at the appliance, turn the gas off at the cylinder.
- Smother the flames with a wet cloth
- If there is a fire at the cylinder or you cannot get to the valve to turn it off**
- call the fire brigade
- direct a garden hose to the middle of the cylinder to keep it cool, however do not extinguish the flame. If the gas is burning it wont build up and explode
- Evacuate the area

A note on fire prevention:

Most fires in outdoor BBQs are caused by a build up of greases and fat, or gas connections which have not been secured properly. Remember to follow the manufacturer's instructions on proper cleaning and connection procedures.

INSECTS

Spiders and insects can occasionally spin webs or make nests in the burner tubes and the jet flame ignition. This can result in a weaker performance from the jet flame, which when ignited should extend to roughly four inches in length. Obstructions in the burners and the ignition can affect gas flow which could result in a fire. This is known as "Flashback" and can cause serious damage to the BBQ and create an unsafe operating environment. Frequent inspection and cleaning of the burner tubes and the jet flame ignition is recommended. Please see illustration below demonstrating how to clean.

CARE AND SAFETY ADVICE

- **TAKE CARE** Grills are heavy
- Clean grills after each use for continued optimum performance.
- Roasting dishes can be placed on top of the grills.
- Ensure that the drip tray is lined with fat absorbent material such as fatsoak or sand before using.
- For safety and optimum performance ensure that your barbecue is on a level, solid surface.
- Empty the fat cup responsibly after each use.

WARRANTY

All of our Grillstream BBQs and accessories are built to last. Our materials are carefully considered with longevity and safety in mind, the technology used in our products is second to none, and all of this is backed up with our friendly customer care team who are on hand for advice and assistance. Our Grillstream limited warranties are 10 years, giving you extra peace-of-mind. The warranty applies to the original purchaser from the date of purchase and covers manufacturing faults and defects only. If an item should fail as a result of a manufacturing fault or defect under normal domestic use, the manufacturer at their discretion will repair, refinish or replace the failed item.

The manufacturer reserves the right to substitute failed items with similar parts / products, should the model or colour no longer be available. Any replacement will be for the failed item only not a complete unit. The original warranty period is not extended in the event of a repair, refinish or replacements. In the event of a failure, it is the customer's responsibility to return the item to the store of purchase along with a copy of the receipt. Warranty specifically excludes general wear and tear, rusting of steel components and parts, corrosion, commercial use and damage caused as a result of failure to observe reasonable care, maintenance and assembly instructions.

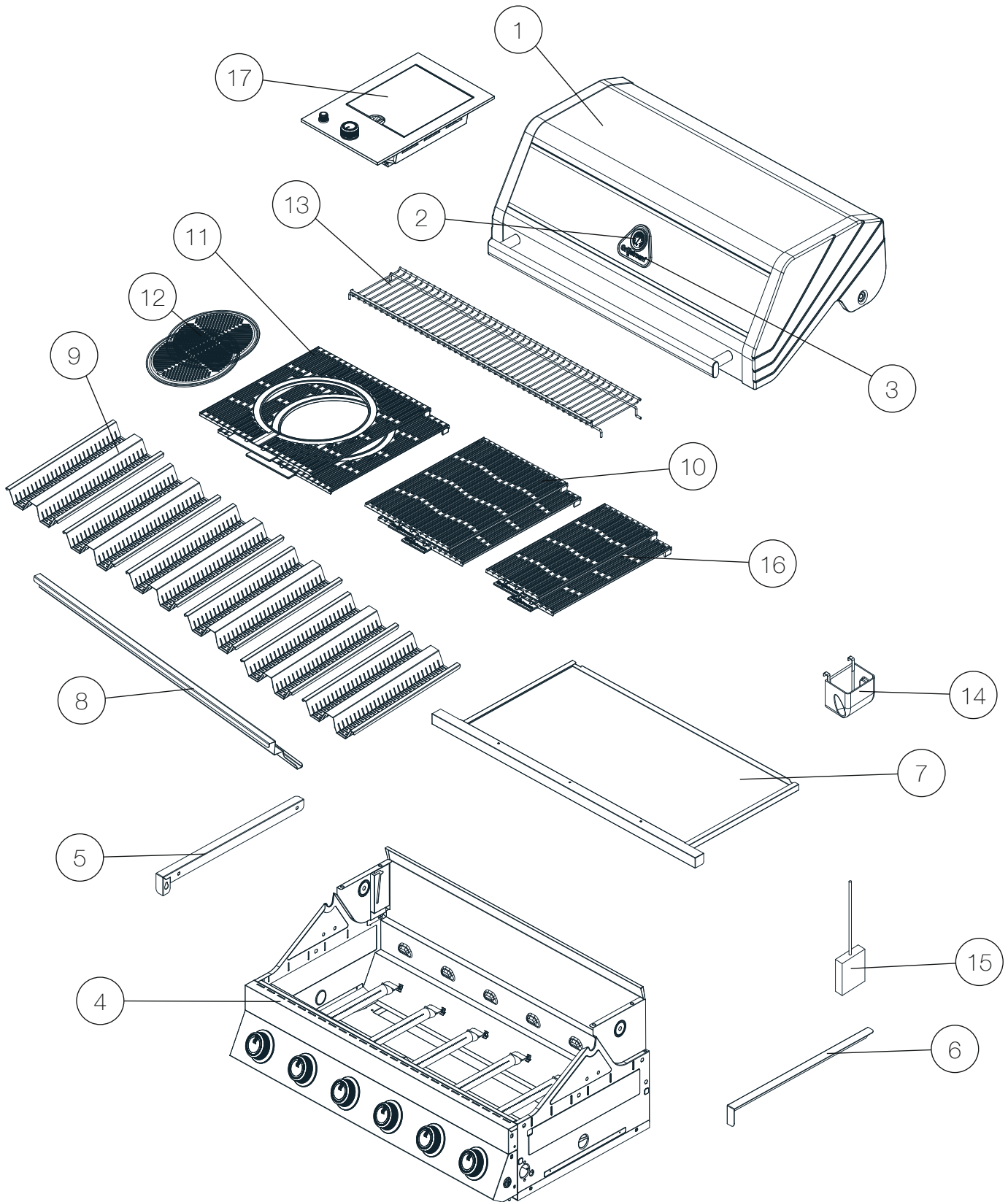

In all instances where a product is not covered by one of our limited warranties a standard 12 month warranty will apply. Below is a list of the limited warranties we currently have in place for Grillstream Barbecues:

- Dual Skin Hood:** 10 year limited warranty, which excludes mechanical damage
- Jet Flame Ignition, Manifold and Valve System (Excluding Side Burners):** 3 year limited warranty
- Burners against corroded through:** 3 year limited warranty
- Grillstream Grills against corroded through:** 3 year limited warranty
- Flame Tamers against corroded through:** 2 year limited warranty
- *All other parts are covered by a 1 year warranty against manufacturing defects



No.	Description	QTY	No	Code	QTY
1	Hood	1	10	295mm Grillstream Grill	2
2	Thermometer	2	11	395mm Grillstream Gastro Grill	2
3	Grillstream Logo Plate	1	12	Circular Griddle Plate	1
4	Cooking Frame	1	13	Warming Rack	1
5	Cooking Frame Support - Left	1	14	Fat Cup	1
6	Cooking Frame Support - Right	1	15	Battery Box	1
7	Grease Tray	1	16	195mm Grillstream Grill	2
8	Fat Channel	1	17	Side Burner	1
9	Hybrid Flametamer	4			

|| FITTINGS

Part	A		Part	B	
QTY	4	M6 Nut	QTY	6	M6 x 20

Whilst we recommend using the LGOutdoor brand built in outdoor kitchen in conjunction with this grill, if you do use your own outdoor kitchen or structure, please ensure it meets the minimum dimensions laid out in Step 4 and that the cooking frame is securely attached to your outdoor kitchen or structure. Please ensure your outdoor kitchen or structure is rated to take the weight of the BBQ and can withstand the operating temperatures when in use.

Caution: Although we take every effort to ensure that the assembly process is as easy as possible, it is inherent with fabricated steel parts that corners and edges can cause cuts if improperly handled during assembly procedures. Be careful while handling any parts during assembly. It is strongly recommended that you protect hands with a pair of work gloves.

|| TOOLS REQUIRED (NOT SUPPLIED)

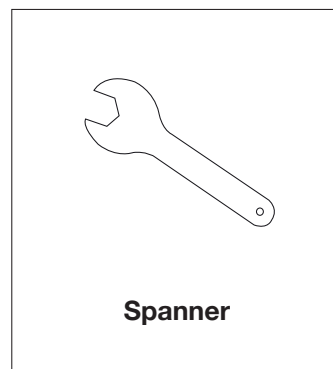

|| PREPARE FRAME FOR ASSEMBLY

Lift hood, remove & unpackage all items except burners & burner assembly.

Proceed to step 1

|| STEP 1

Unscrew bolt located at front of control panel, as indicated. Attach Cooking Frame Support - Right (6) using 2 x Bolt (2) and 2 x Nut (1). Bolts screw from inside of cooking frame with Nuts to be located on outside. Now replace the bolt removed from control panel. Repeat for Cooking Frame Support - Left (5).

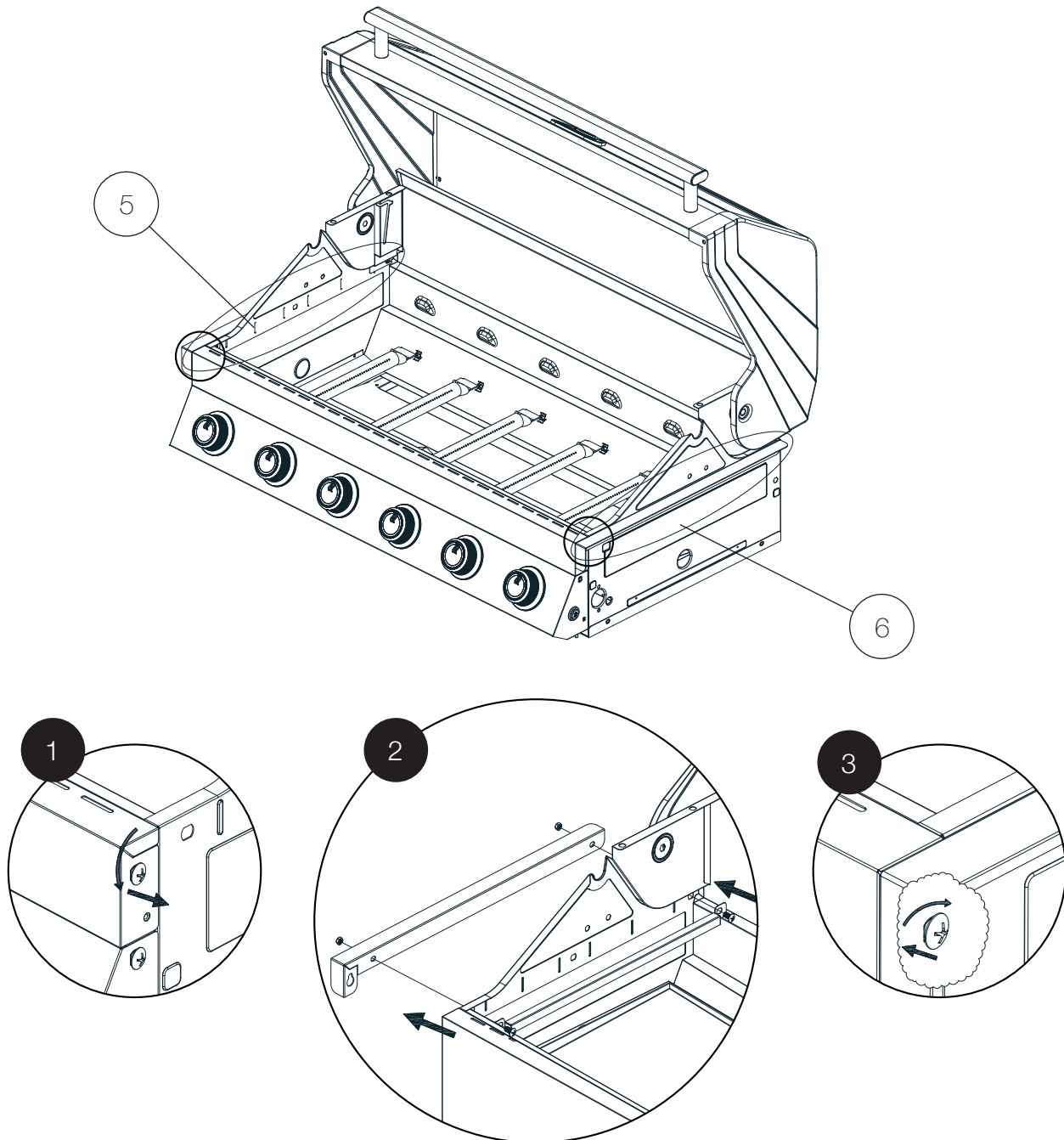

|| STEP 2

Unscrew and remove Wingnut and Washer from Thermometer (2). Thread Thermometer Spindle through Grillstream Logo Plate (3) and then through Glass Window of Hood (1). Replace Washer and Wingnut. Note: Do not overtighten as this could lead to damaging of the Glass Window.

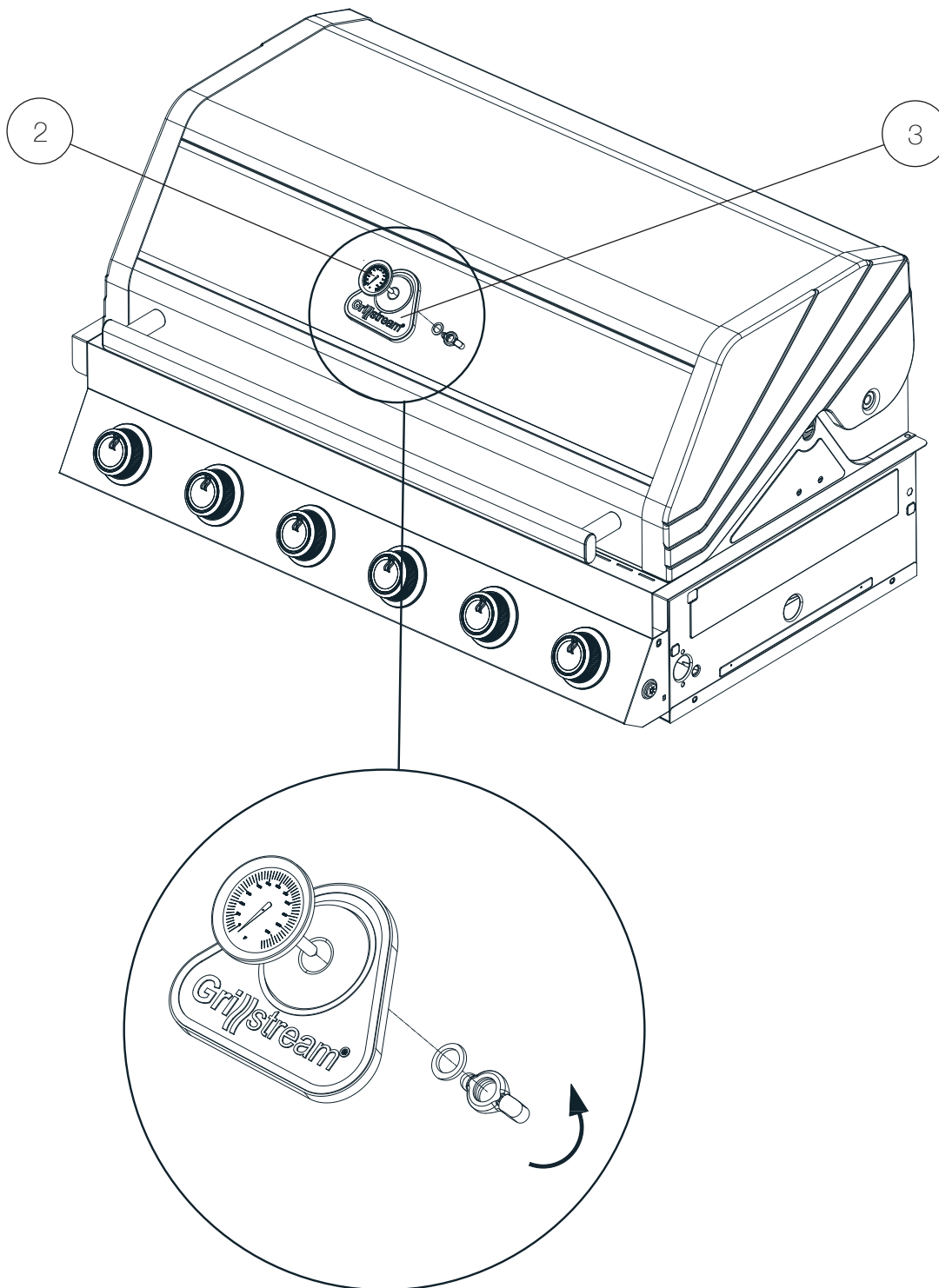

|| STEP 3

Slide Grease Tray (7) underneath Cooking Frame ensuring it is level and on top of runners. The Gas Hose will be attached behind the Control Panel via cable tie, please cut the cable tie carefully to avoid damaging the components behind the Control Panel. Attach hose as instructed in the SECURING THE HOSE AND REGULATOR ASSEMBLY section and ensure you perform a gas leak before use.

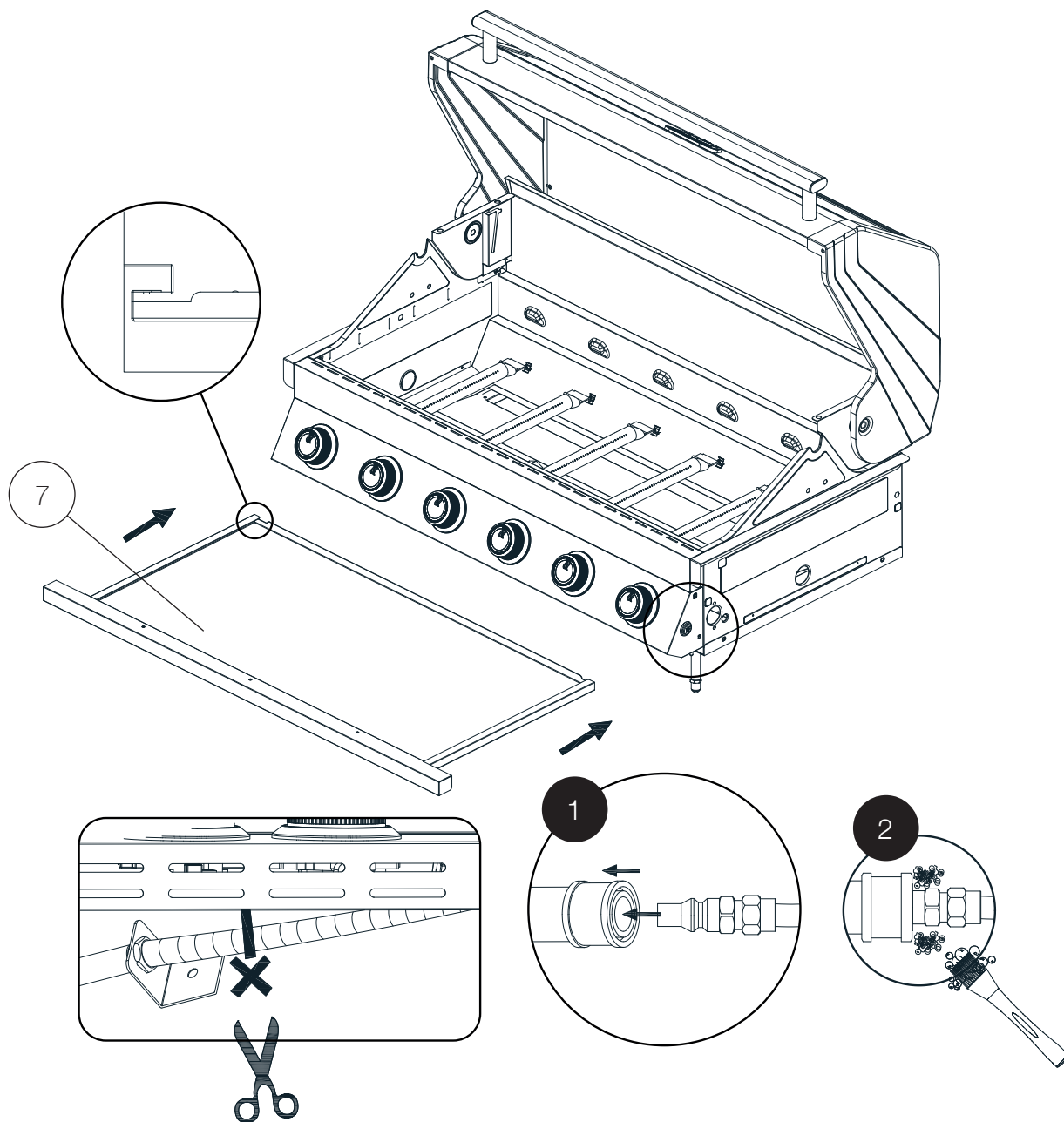

|| STEP 4

Install the Built-In Cooking Frame (4) and Side Burner (17) into your Outdoor Kitchen setup ensuring there is access to the Grillstream Fat Cup (14) for easy removal and replacement. Now connect Side Burner hose to Cooking Frame as instructed in the SECURING THE HOSE AND REGULATOR ASSEMBLY section and ensure you perform a gas leak before use.

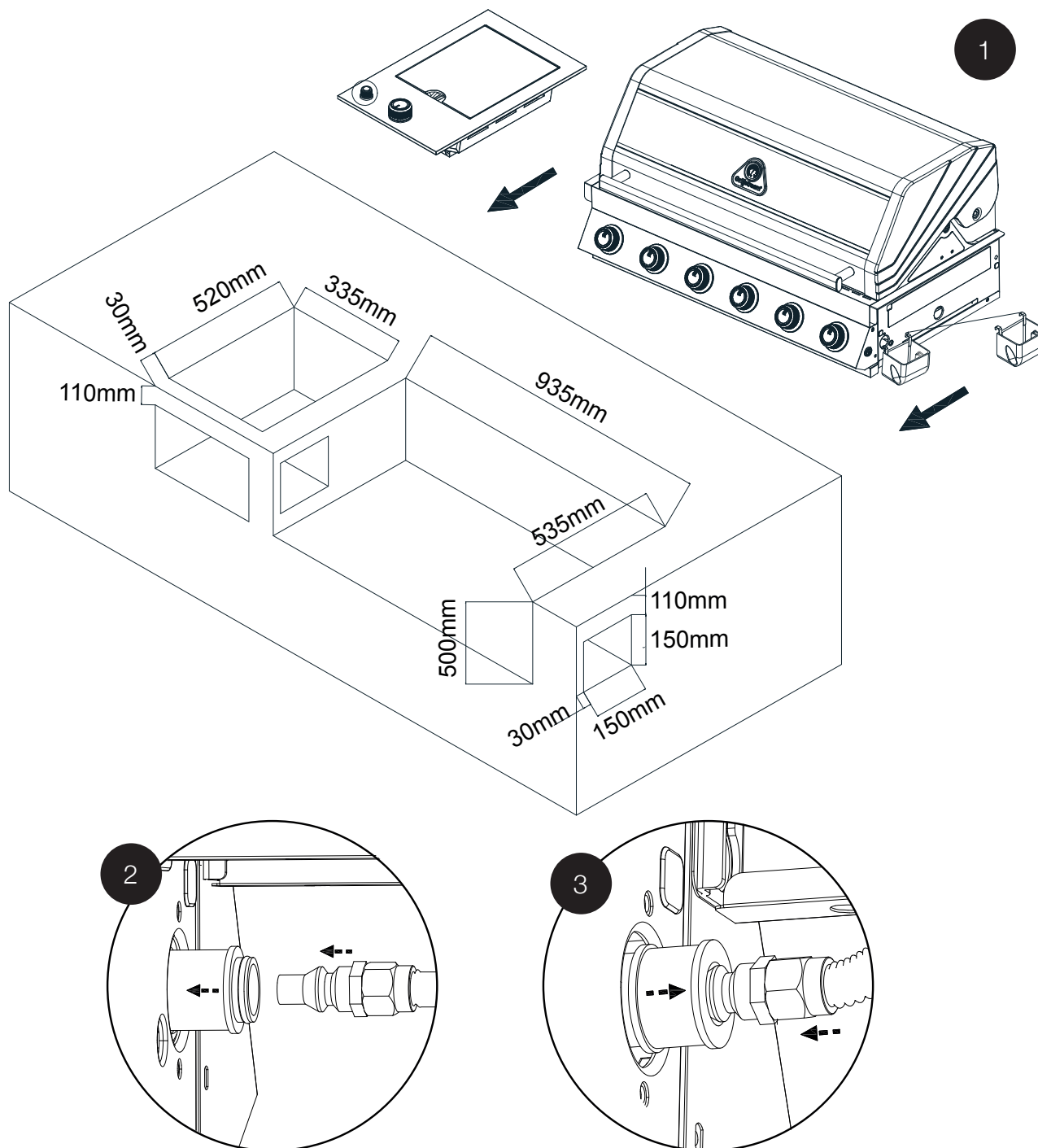

|| STEP 5

Place Hybrid Flame Tamers (9) on locating shelves. Flame Tamers should sit directly above Tube Burners. Insert Fat Channel (8) into Cooking Frame by first sliding thin end through right-hand side of Cooking Frame and then slotting front lip in groove between Cooking Frame and Control Panel.

Place Grillstream Grills (10 & 16), Grillstream Gastro Grills (11) and Circular Griddle Plate (12) into Cooking Frame. Leg tabs from bottom Grillstream Grills and Grillstream Gastro Grills should rest on lip at back of Cooking Frame with the logo tab at the front. Top Grillstream Grills should sit directly on top of the bottom Grills.

The Circular Griddle Plate should rest on top of the upper Grillstream Gastro Grill above the cutout section. You can also swap out the Circular Griddle Plate for a variety of Grillstream Gastro Accessories including a Pizza Stone, Wok or Chicken Roaster (sold separately) for a varied cooking experience.

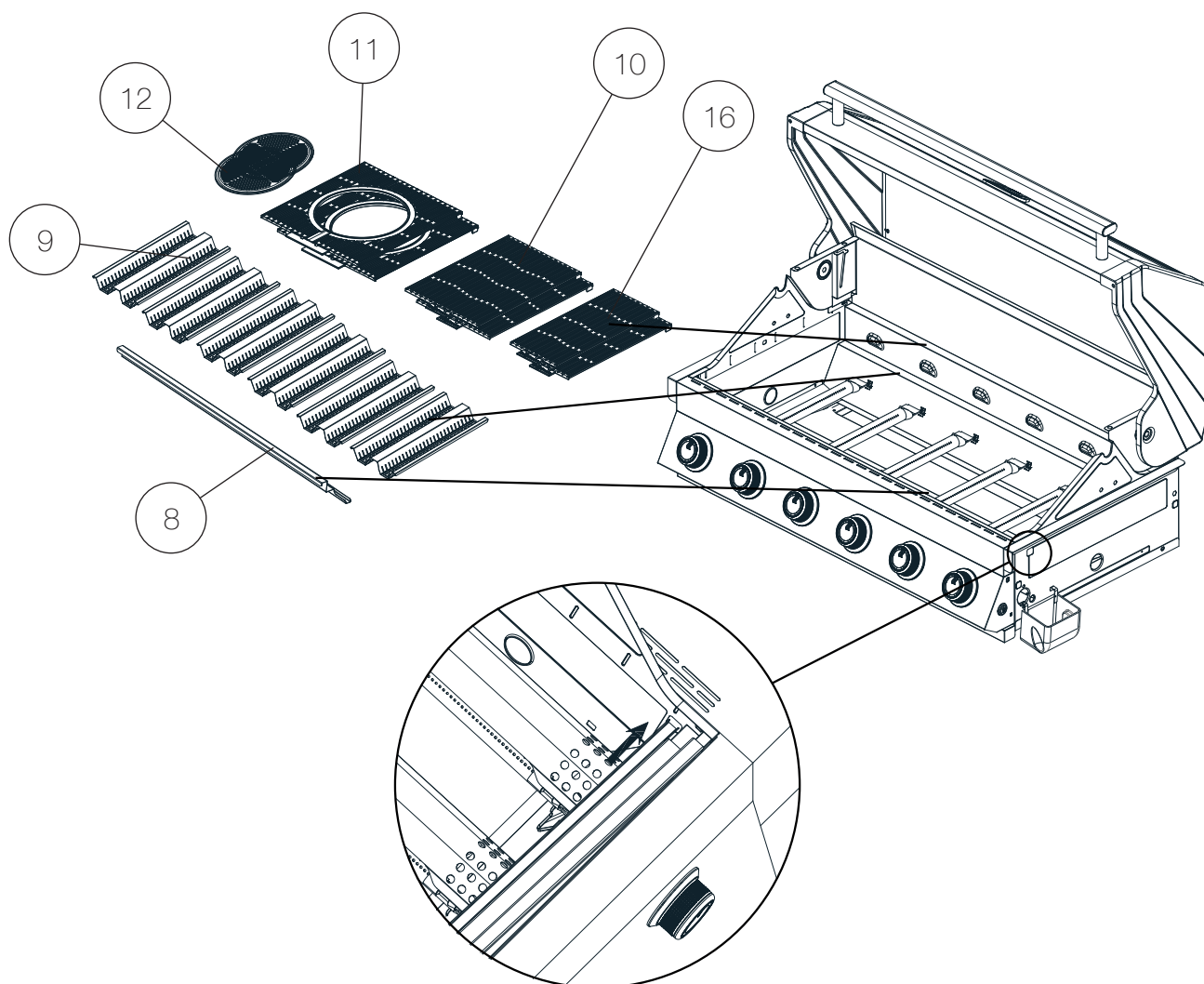

|| STEP 6

Insert back legs of Warming Rack (13) into channel on Warming Rack Clips. Angle Warming Rack forwards and insert front legs into holes located on Cooking Frame (4).

To operate, lift front legs out of holes in Cooking Frame and tilt Warming Rack upwards. Pull Warming Rack forwards slightly so back legs are inline with vertical track and slide downwards.

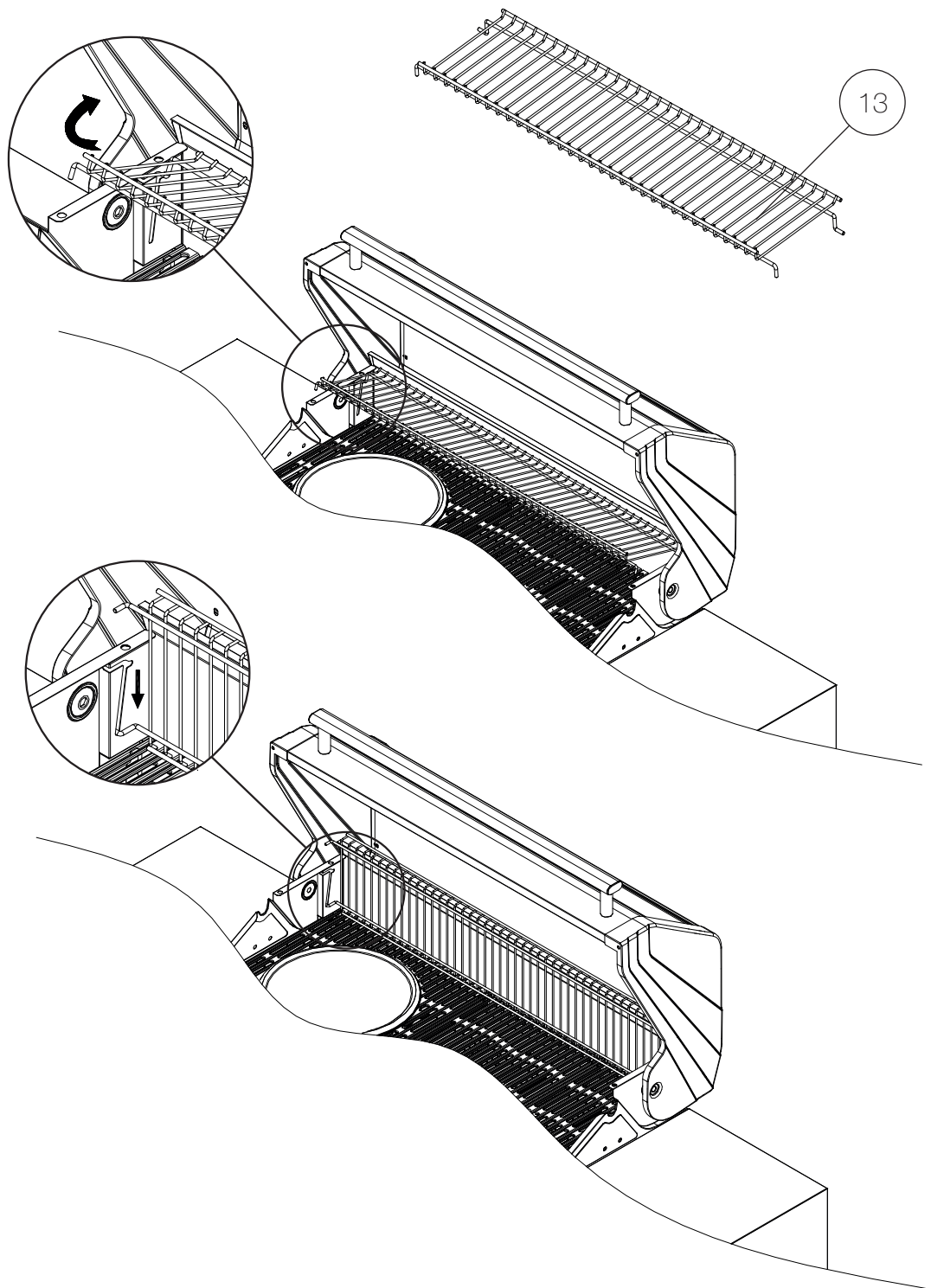

|| STEP 7

Insert 4 x AA Batteries (not supplied) into Battery Pack (15). Connect Battery Pack to LED Light Wire. Peel off plastic backing from sticky pad on the rear of the Battery Pack and affix to inside of Outdoor Kitchen away from sources of heat.

The On/Off switch for the LED Control Knob function is located to the right of the control panel. Use this to enable or disable the LED function. Note: The Control Knobs will light up then change colour individually when they are twisted to the on position to indicate which burners are active.

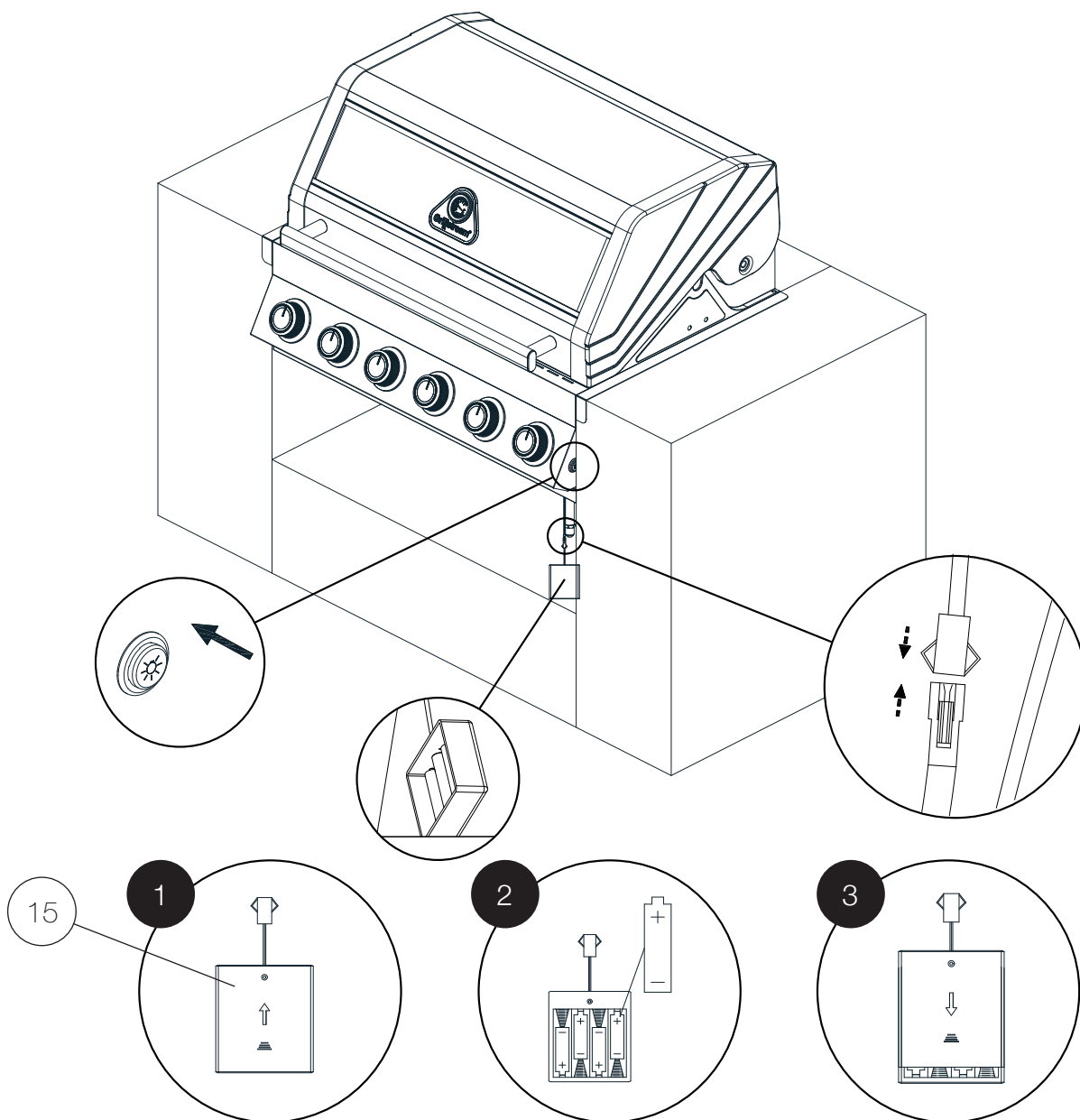

|| TESTING YOUR BBQ

TESTING FOR LEAKS - DO THIS BEFORE USING YOUR BBQ. Note - Do not test for gas leaks with an open flame. If you smell gas, turn off at the source.

Before first use, at the beginning of each new season, or whenever a gas cylinder is changed, you must check for gas leaks.

Do so by:

1 Turn all gas valves on the BBQ to the off position

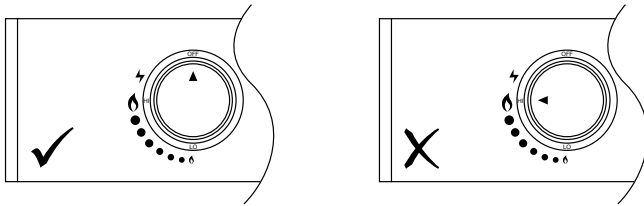

2 Turn on the gas cylinder

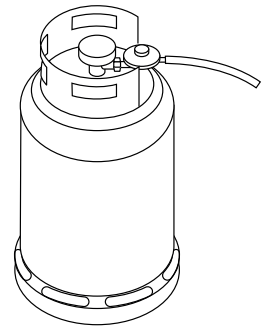

3 Make a soap solution of one part liquid detergent and one part water

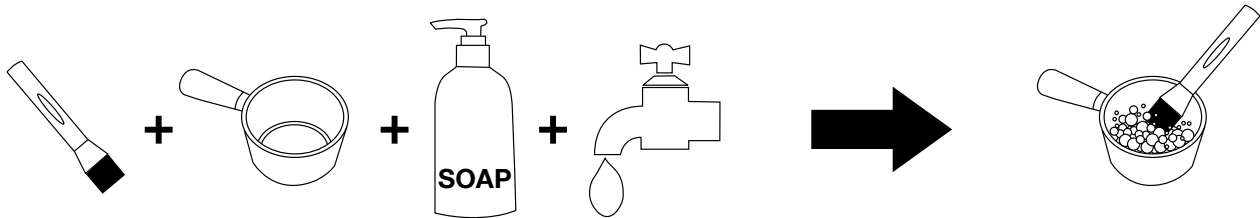

4 Brush the soap solution over all gas connections

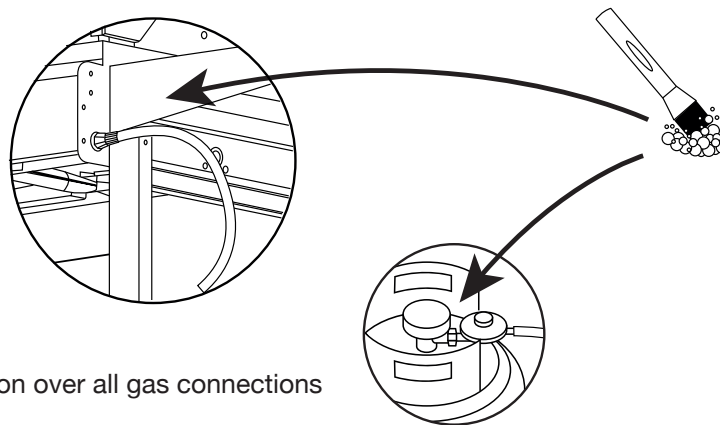

- 5**
- The presence of bubbles indicates a leak. Tighten or repair as necessary
 - Under no circumstances should a naked flame be used to check for leaks
 - If a gas odour is present and no leaks can be found, do not use the BBQ. Turn the gas off at the source, disconnect the hose and immediately contact your BBQ dealer or place of purchase for assistance

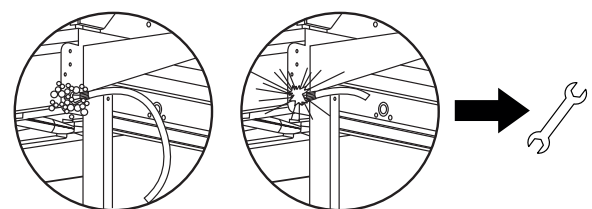

**PLEASE KEEP THESE INSTRUCTIONS FOR
FUTURE REFERENCE**

Grillstream Barbecues
Part of the LeisureGrow Group
Dewmead Farm,
New Inn Road,
Hinxworth,
Hertfordshire SG7 5HG,
United Kingdom.
Tel: +44 (0)1462 744500
E-mail: consumer@leisuregrow.com