

IMPORTANT! PLEASE KEEP THESE INSTRUCTIONS FOR FUTURE REFERENCE

Wilton 90cm Child Compliant Bed

Stock code natural: 803/42901

Stock code white: 803/42423

Stock code dark: 803/42523

Single

Thank you for purchasing this Wilton child compliant bed. Please read the instructions carefully before use to ensure safe and satisfactory operation of this product.

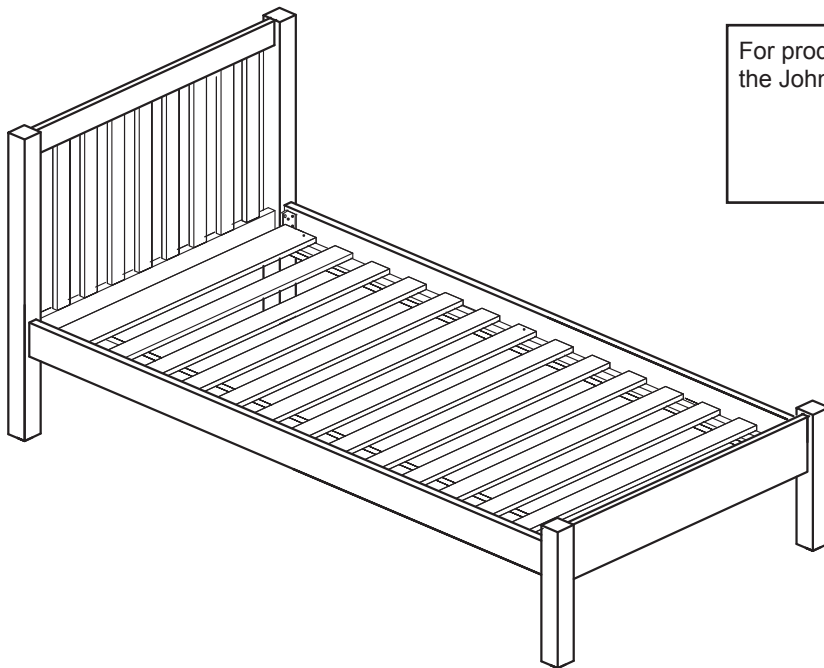

For product support or spare parts please call the John Lewis Helpline;

T: 01244 689949

E: mail@fwgroup-uk.com

PRE-ASSEMBLY PREPARATION

Please ensure instructions are read in full before attempting to assemble this product.

Necessary Tools



Please check the pack contents before attempting to assemble this product. A full checklist of components is given in this leaflet. If any components are missing, please contact the John Lewis Helpline.

This product is **HEAVY**. It should be assembled as near as possible to the point of use. **TAKE CARE WHEN LIFTING** to avoid personal injury and (or) damage to the product.

This product takes approximately **40 MINUTES** to assemble with **2 PEOPLE**.

The fittings pack contains **SMALL ITEMS** which should be **KEPT AWAY FROM YOUNG CHILDREN**.



Read this leaflet in full before commencing assembly.

If you require any additional information or have any issues with this product please call the John Lewis Helpline on 01244 689949 or email mail@fwgroup-uk.com

IMPORTANT! PLEASE KEEP THESE INSTRUCTIONS FOR FUTURE REFERENCE

Fittings and parts checklist

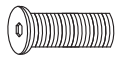
Fittings

A	Allen Key - 4mm x 1 pcs		B		Bolt x 8 pcs (M8 x 22)
C	Screw x 28 pcs (Ø 4 x 30 mm)				

Parts

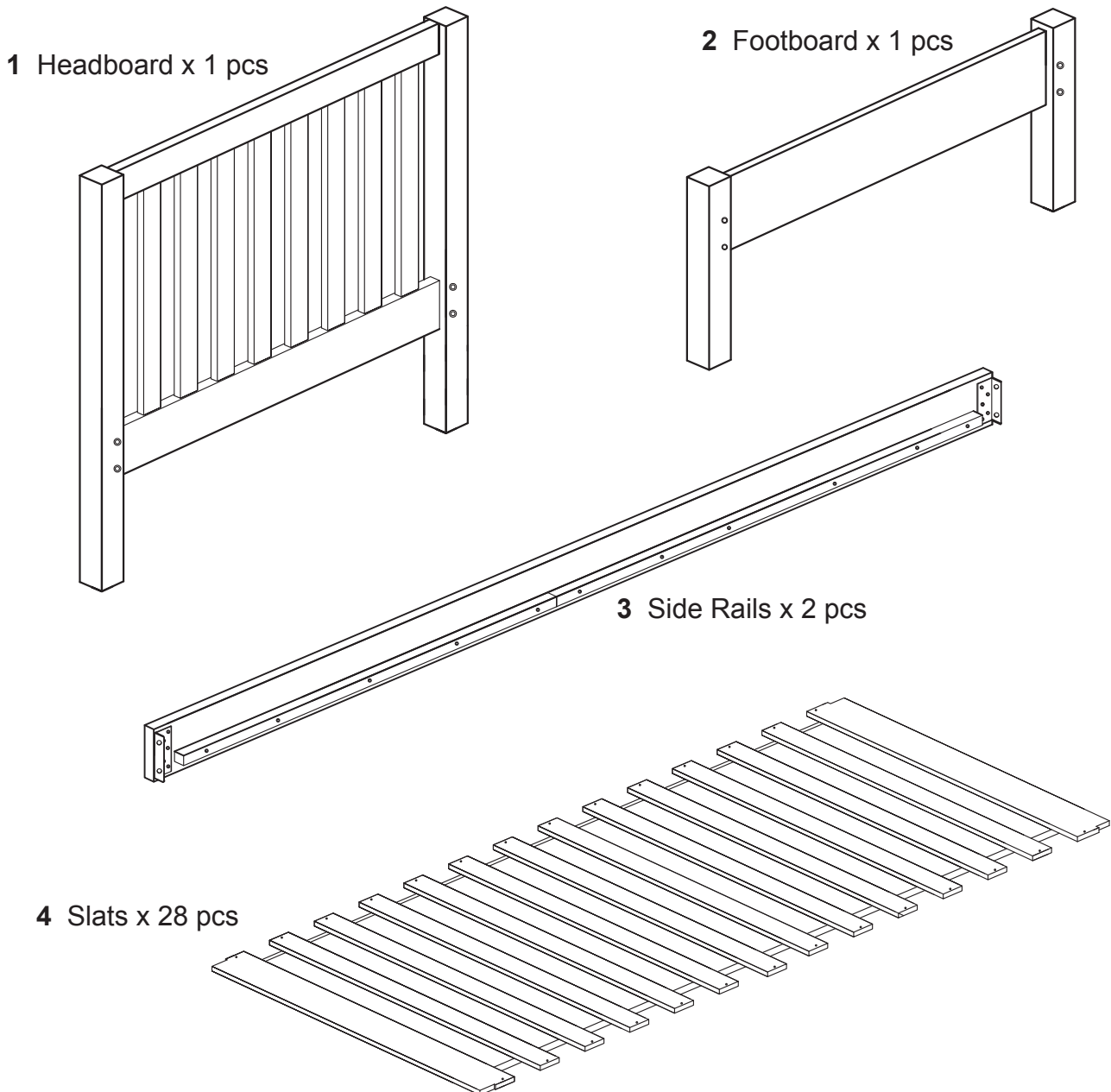

IMPORTANT! PLEASE KEEP THESE INSTRUCTIONS FOR FUTURE REFERENCE

Step One

Attach the Side Rails (3) to the Headboard (1) using Bolts M8 x 22mm (B). Tighten with Allen Key (A).

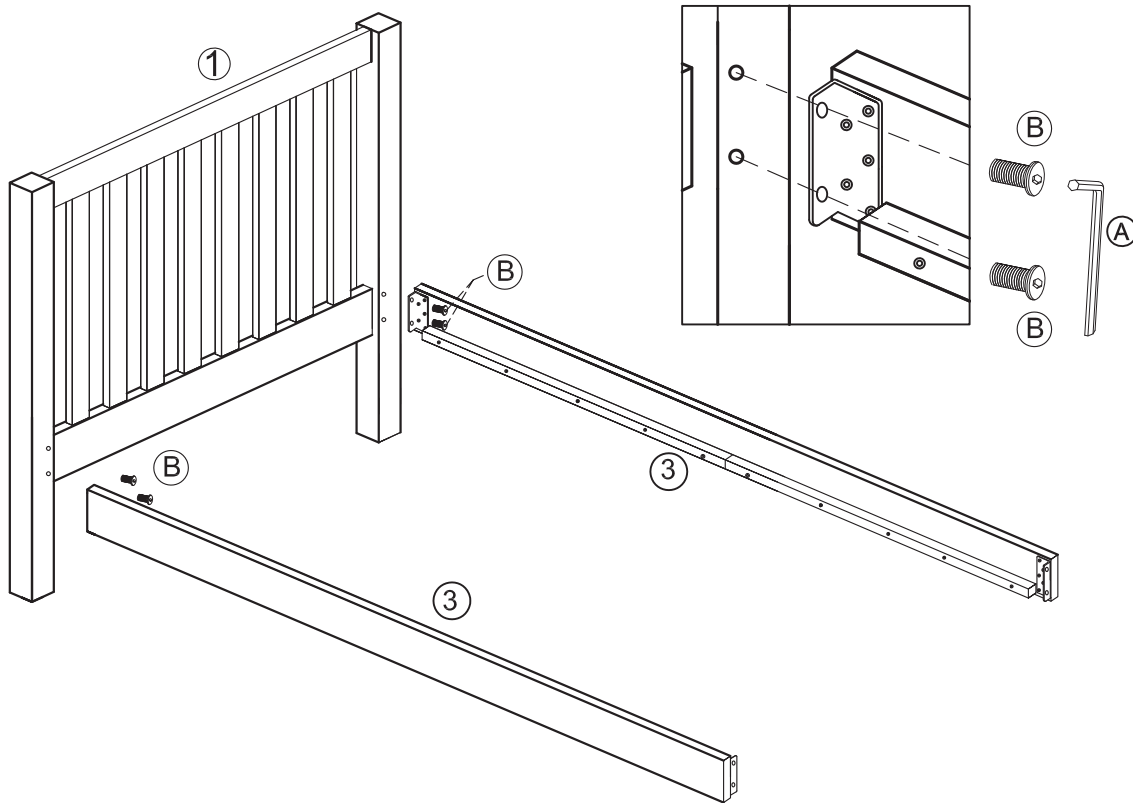

Step Two

Attach the Side Rails (3) to the Footboard (2) using Bolts M8 x 22mm (B). Tighten with Allen Key (A).

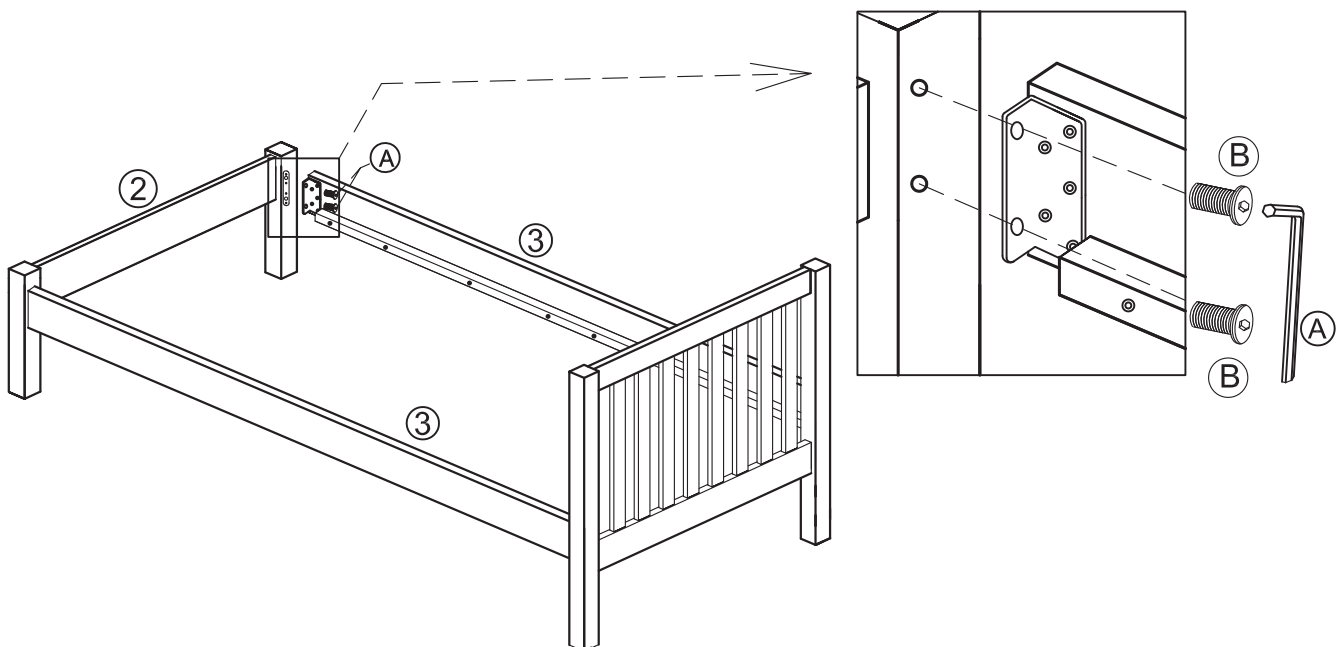

IMPORTANT! PLEASE KEEP THESE INSTRUCTIONS FOR FUTURE REFERENCE

Step Three

Place the one of the widest slats at the top of the headboard, and hold in place while you pull the rest of the slats down towards the footboard. Fix the Slats (4) at both ends using Screws $\varnothing 4 \times 30\text{mm}$ (C).

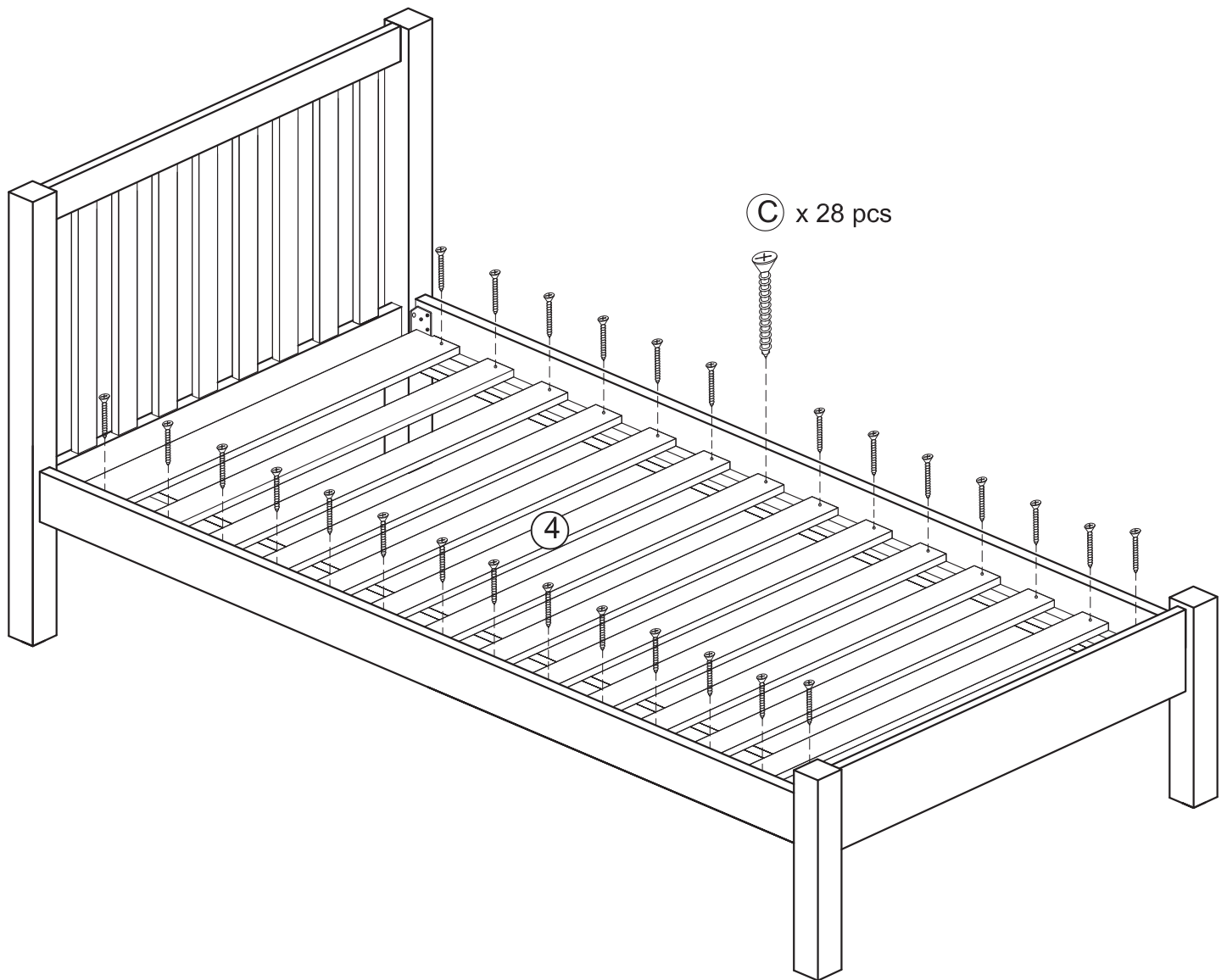

This bed is now ready to use.

IMPORTANT! PLEASE KEEP THESE INSTRUCTIONS FOR FUTURE REFERENCE

Care and Maintenance

Wood furniture

Wood displays different grain patterns depending on which way they cut - for example, the 'medullary ray' which can appear on oak furniture is a mark of good quality timber - these are just characteristics of the natural beauty of the wood. Some furniture is also deliberately aged and rustic.

Wood veneer also allows distinctive patterns to be created on flat surfaces, such as table tops and drawer fronts by the way the slivers are arranged.

All timber surfaces will change colour and mellow over time. New furniture will initially vary in shade from items that have been previously purchased.

How to care for your wood furniture

Furniture with a hard lacquer, wax polish or painted surface should be dusted with a dry cloth.

Wax furniture will need to be given a coat of beeswax a couple of times a year to help maintain its lustre.

Spray polishes are best avoided as they contain silicones which may spoil the furniture's surface by building up over time.

Our furniture will endure most temperatures in the home but it is best to avoid placing furniture next to heat sources such as radiators or fires. Be particularly careful with solid wood as the lack of humidity caused by central heating can cause damage such as warping.

IMPORTANT! PLEASE KEEP THESE INSTRUCTIONS FOR FUTURE REFERENCE

Safety Instructions

Never drag furniture when moving it. Always lift it.

Periodically check all fixings to ensure none have come loose and re-tighten when necessary.

Please take care when handling or moving the furniture as careless handling may cause damage or injury.

Furniture can be dangerous if incorrectly installed. Any assembly should be carried out by a competent adult.

No liability will be accepted for damage or injury caused by incorrectly installed or assembled furniture.

During assembly, children should be kept away from the product due to possible risk of injury.

Do not use this item if any components are missing or damaged.

It is recommended that care is taken when moving heavy objects to a new location to avoid personal injury or damage to the furniture. Please be careful to retain all fittings when doing this.

Children are likely to play, bounce, jump and climb on furniture, therefore the furniture should not be placed too close to other furniture or windows, blind cords, curtain pulls or other strings or cords and should be placed either tight to any wall or have a gap of 300mm between the wall and the side of the bed.

This product complies with BS 8509:2008+A1:2011.

If you need any additional information or have any issues with this product please call the John Lewis helpline on 01244 689949 or email mail@fwgroup-uk.com